

SAMSUNG

EHS

Technical Data Book

EHS Mono R290 for Europe
(R290, 50Hz, HP)

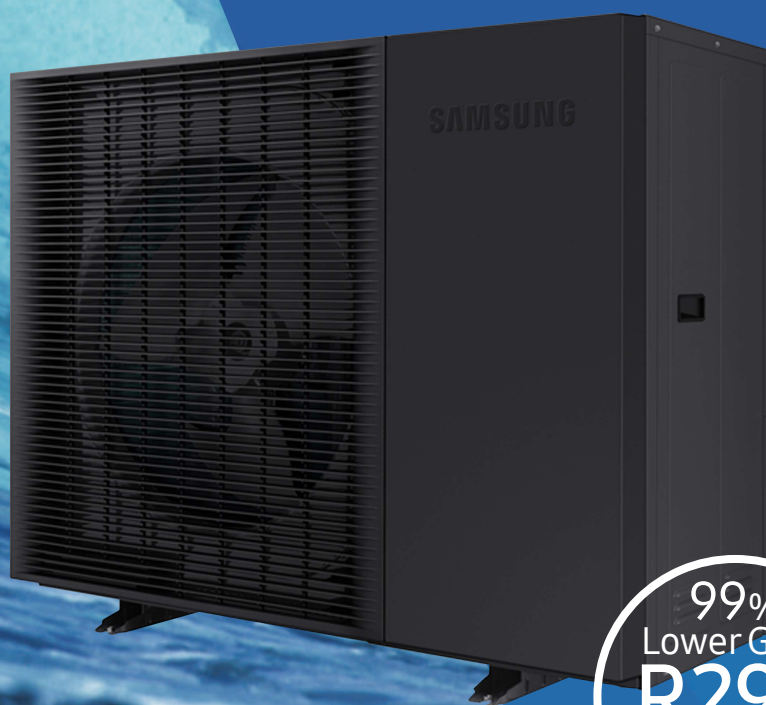

Model : Outdoor unit (AE***CXD*K/EU)
Hydro unit (AE***CNW*M/G/EU)

History

Version	Modification	Date	Remark
Ver.1.0	Released EHS Mono for Europe TDB (R290, 50Hz, HP)	23. 06. 15	
Ver.1.1	Updated the final Specification	23. 08. 17	
Ver.1.2	Updated the Control kit Specification	23. 11. 30	

Nomenclature

Model Name

AE	160	C	X	Y	D	G	K	/	EU
(1)	(2)	(3)	(4)	(5)	(6)	(7)	(8)		Buyer

(1) Classification

AE	EHS
-----------	-----

(5) Feature 1

Y	MONO
----------	------

(2) Capacity

X 1/10 kW (3 digits)

(6) Feature 2

D	DELUXE
----------	--------

(3) Version

C	2023
----------	------

(7) Rating Voltage

E	220~240V, 50Hz, 1Φ
G	380~415V, 50Hz, 3Φ

(4) Product Type

N	Indoor Unit
X	Outdoor Unit

(8) Mode

K	Heat Pump (R290)
----------	------------------

Nomenclature

Model Name

AE	200	C	N	W	M	E	G	/	EU
(1)	(2)	(3)	(4)	(5)	(6)	(7)	(8)		Buyer

(1) Classification

AE	EHS
-----------	-----

(5) Product Notation

W	Tank integrated hydro unit
----------	----------------------------

(2) Capacity

x Liter (3 digits)

(6) Feature

M	Mono
----------	------

(3) Version

C	2023
----------	------

(7) Rating Voltage

E	220~240V, 50Hz, 1Φ
G	380~415V, 50Hz, 3Φ

(4) Product Type

N	Indoor Unit
X	Outdoor Unit

(8) Mode

G	Heat Pump (R32)
----------	-----------------

Features & Benefits

EHS Mono R290



Highlights



R290 Refrigerant

The natural R290 refrigerant helps conserve the ozone layer and has less impact on global warming.



Hot Water Temperature of up to 75°C

Enjoy a consistent supply of extremely hot water of up to 75°C.



Low Sound Level of 35dB(A)

Make less noise whenever you need.

Features & Benefits

EHS Mono R290

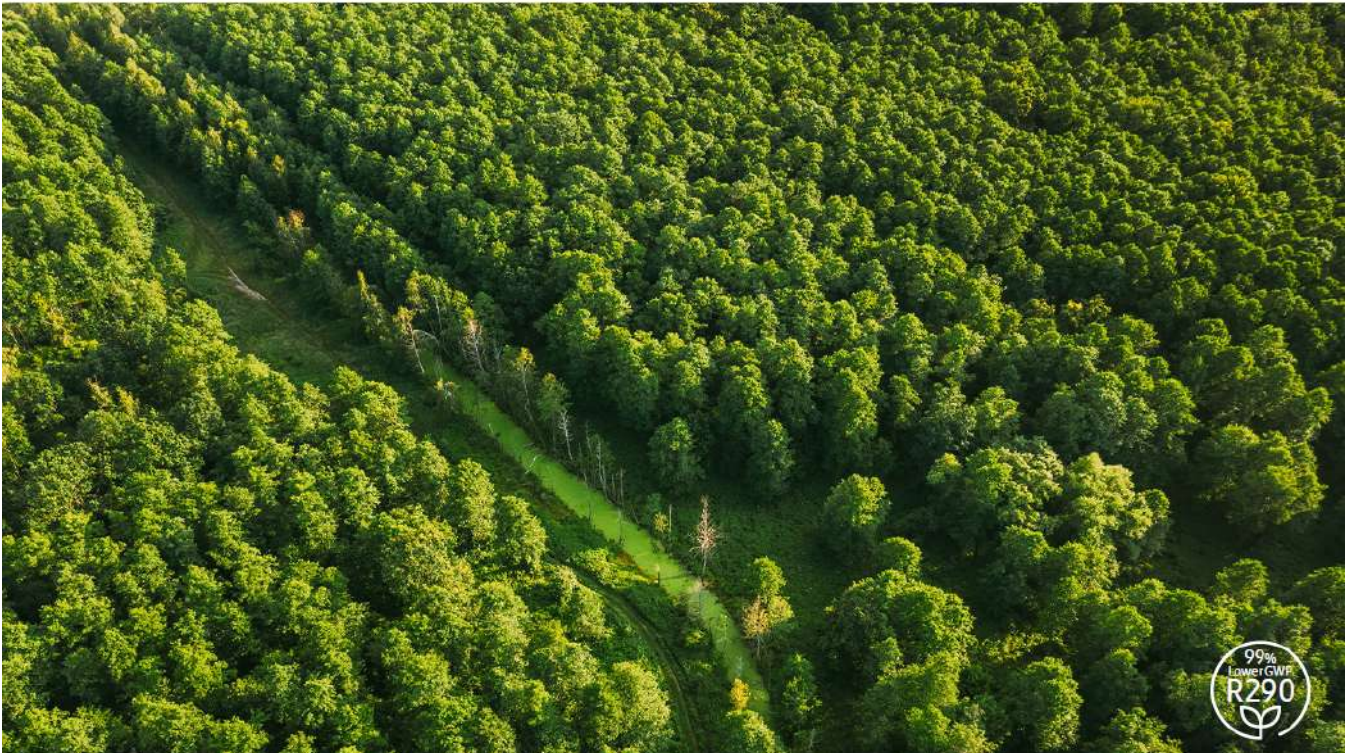

R290 Refrigerant

The natural R290 refrigerant has an Ozone Depletion Potential (ODP) of zero and a Global Warming Potential (GWP) of 3, which is lower than conventional R32 or R410A refrigerants*. It also has a reinforced design with 5 layers of safety features to reduce the risks of using the R290 refrigerant.

* GWP by refrigerant: R290 = 3, R32 = 675, R410A = 2088.

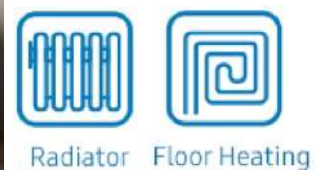
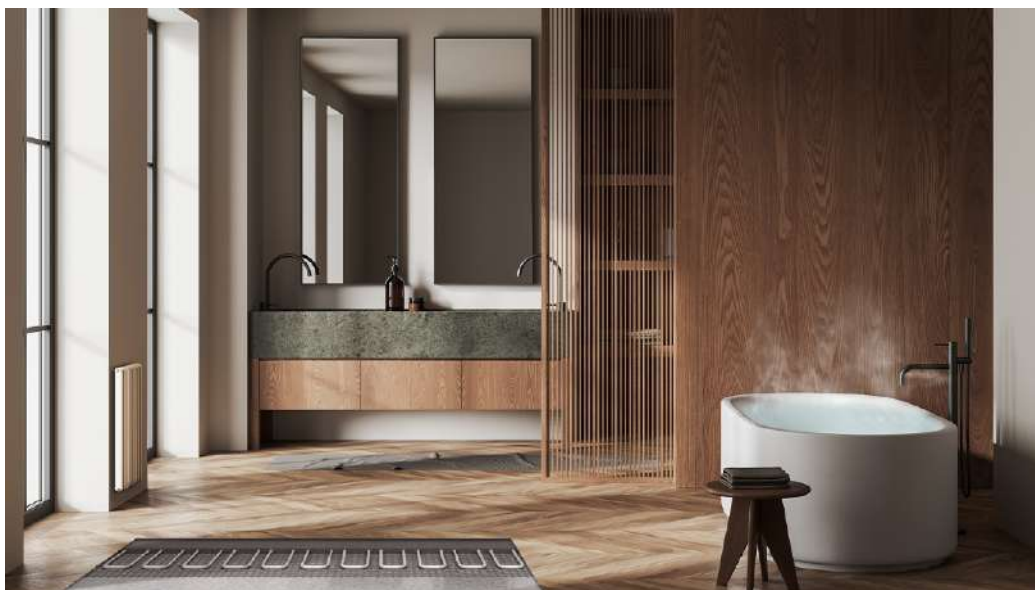

Creates extremely hot water – up to 75°C

Enjoy a supply of extremely hot leaving water of up to 75°C*, which enables effective convection heating and provides sanitary water. It improves energy efficiency**, as it can supply sanitary water of up to 70°C*** using only a Heatpump. And it is hot enough to kill Legionella bacteria****.

* Leaving water temperature from an outdoor unit is 75°C when the outdoor temperature is -10~35°C. Sanitary water leaving a DHW tank is 70°C when the outdoor temperature is -10~43°C. Results may vary depending on the actual usage conditions.

** Based on internal testing compared to a conventional model AE***RXYD*G/EU.

*** Leaving water temperature of sanitary hot water, when the outdoor temperature is between -10~43°C. If the outdoor temperature is lower than -10°C, a Booster Heater is required. Results may vary depending on the actual usage conditions.

**** Sanitary hot water should be stored at 60°C or higher in order to kill Legionella bacteria.

Features & Benefits

EHS Mono R290

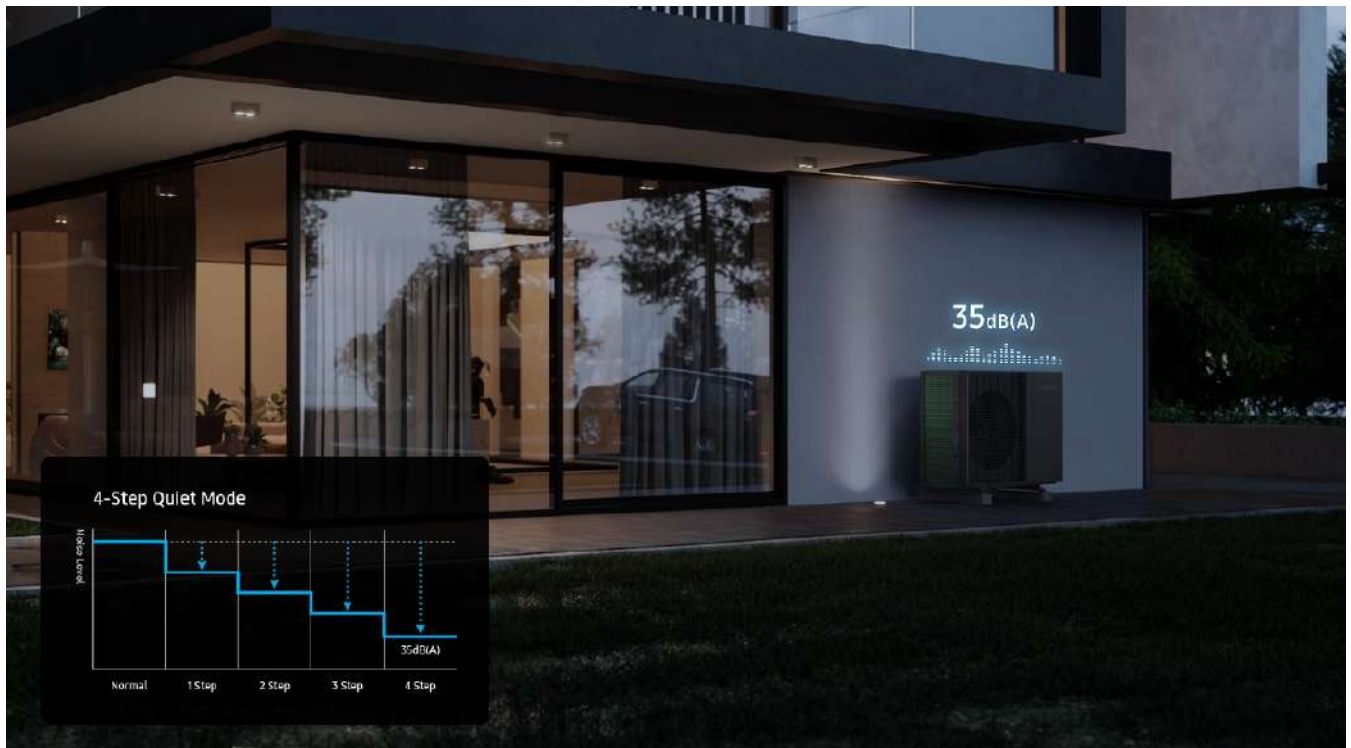

Adjustable, 4-step, low-noise operation Low Sound Level of 35dB(A)

Make less noise whenever you need. The 4-Step Quiet mode* enables adjustable low-noise operation to meet the noise level regulations in European countries. Simply select from four different steps and reduce the sound level by 3dB, 5dB, 7dB or keep it as low as 35dB(A)*** to reduce disturbance.

* The heating performance may be reduced when operating in Quiet mode.

** The Technical Instructions on Noise Abatement (German: TA-Lärm) contain regulations for protecting the general public or neighborhood from noise emissions.

*** Based on internal testing. The noise level is measured 3m away from the front of the outdoor unit. Results may vary depending on environmental factors and individual use.

Enhanced efficiency High Efficiency (SCOP A+++)

Enjoy consistently high energy savings. It has an enhanced Seasonal Coefficient of Performance (SCOP) A+++ energy efficiency rating across the whole range of capacities*. It has been increased by up to 14%** compared to conventional models and is up to 15% more than the A+++ rating criteria***.

* Based on internal testing when generating 35°C water, in accordance with EN14825. Results may vary depending on the system configuration and actual usage conditions.

** Based on internal testing when generating 35°C water using an EHS R290 Mono 5kW model, AE050CXDEK/EU (SCOP: 5.10), compared to an EHS R32 Mono model of the same capacity, AE050RXYDEG/EU (SCOP: 4.46).

*** Based on internal testing when generating 35°C water using an EHS R290 Mono 5kW model, AE050CXDEK/EU (SCOP: 5.10), compared to the criteria of A+++, SCOP≥ 4.45.

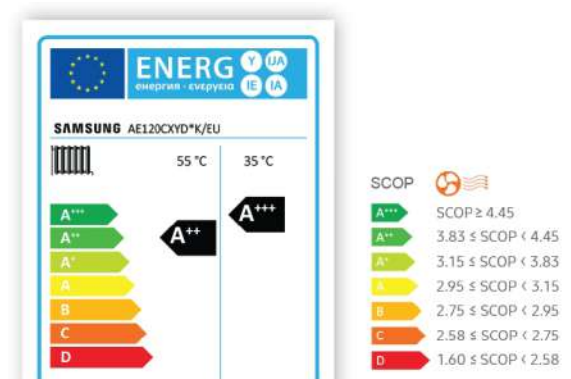



Contents

1. Line-up	9
1-1. Outdoor Units	9
1-2. Tank integrated hydro unit	9
2. Outdoor Units	10
2-1. Specifications	10
2-2. Electrical characteristics	18
2-3. Dimensional drawing	19
2-4. Center of Gravity	21
2-5. Electrical wiring diagram	23
2-6. Sound data	25
2-7. Operation range	30
2-8. Piping diagram	31
2-9. Capacity table	33
2-10. Silent mode corrections	38
3. Tank integrated hydro unit	39
3-1. Specifications	39
3-2. Dimensional drawing	45
3-3. Electrical wiring diagram	47
3-4. Sound data	49
3-5. Piping diagram	56
4. Control Kit	57
4-1. Specifications	57
4-2. Dimensional drawing	64
4-3. Electrical wiring diagram	65
5. Installation	66
Tank integrated hydro unit	66
Outdoor Unit	72
Control Kit	89

1.Line-up

1-1. Outdoor unit

Capacity		5.0 kW	8.0 kW	12.0 kW	16.0 kW
Image					
Model	1 phase	AE050CXYDEK/EU	AE080CXYDEK/EU	AE120CXYDEK/EU	AE160CXYDEK/EU
	3 phase	-	AE080CXYDGK/EU	AE120CXYDGK/EU	AE160CXYDGK/EU

1-2. Tank Integrated hydro unit

Type \ Capacity	200 L	260 L
Model	AE200CNWMEG/EU	AE260CNWM*G/EU
Hydro unit		

Model	MIM-E03CN	MIM-E03EN
Control Kit		

2. Outdoor Units

2-1. Specifications

Model Name		Indoor Unit			AE200CNWMEG/EU		AE200CNWMEG/EU			
		Outdoor Unit			AE050CXDEK/EU		AE080CXDEK/EU			
Power Supply				Φ, #, V, Hz	1, 2, 220~240, 50		1, 2, 220~240, 50			
System	Mode			-	Heat Pump (A2W)		Heat Pump (A2W)			
	Performance	Capacity	Heating	A2W Condition #1. (A7/W35) ^{1)*}	W	5,000	8,000			
				A2W condition #2	Btu/h	17,100	27,300			
				A2W condition #3	W	5,000	8,000			
				A2/W35 ^{4)*}		5,000	8,000			
				A-7/W35 ^{4)*}		5,000	8,000			
			Cooling	A2W Condition #1. (A35/W18) ^{1)*}	W	5,000	8,000			
				A2W condition #2	Btu/h	17,100	27,300			
				A2W condition #2	W	3,900	5,700			
				Power Input			W	980	1,630	
				Heating	A2W Condition #1. (A7/W35) ^{1)*}	1,320		2,160		
	A2W condition #2	1,610	2,670							
	A2/W35 ^{4)*}	1,160	1,900							
	A-7/W35 ^{4)*}	1,670	2,670							
	Cooling	A2W Condition #1. (A35/W18) ^{1)*}	W	1,280	2,050					
		A2W condition #2	1,279	1,900						
	Current Input	Heating	A2W Condition #1.	A	4.63	7.70				
					6.05	9.69				
		Cooling	A2W condition #2	A	6.24	10.21				
					7.61	12.62				
		Current	MCA	A	16.1	26.0				
	MFA		A	17.6	28.6					
	Efficiency	COP (Nominal Heating) A2W condition #1				5.10	4.91			
		EER (Nominal Cooling) A2W condition #1				3.91	3.90			
		EER (Nominal Cooling) A2W condition #2				3.05	3.00			
		COP			W/W	A2W condition #2	3.80	3.70		
						A2W condition #3	3.10	3.00		
						A2/W35 ^{4)*}	4.30	4.20		
						A-7/W35 ^{4)*}	3.00	3.00		
						PdesignH (LWT 35°C)	5,500	8,000		
		PdesignH (LWT 55°C)	5,500	8,000						
		SCOP (35°C)	5.10	4.85						
		SCOP (55°C)	3.60	3.55						
		SCOP Class (35°C)	A+++	A+++						
		SCOP Class (55°C)	A++	A++						
		SEER	4.20	4.30						
		Water Connections	Water Flow Rate (Nominal)		Heating	LPM	14.4	23.1		
			Cooling	LPM	14.4	21.6				
	Water Flow Rate		Min	LPM	7	7				
			Max	LPM	48	48				
Water Pressure (Max)			bar	3	3					
Water Pipe Type	threaded male		Inlet	Φ, mm	28	28				
			Outlet	Φ, mm	28	28				
Leaving Water Temperature	Min.		Heating	°C	15	15				
				°C	75	75				
	Max.		Cooling	°C	5	5				
		°C		25	25					
Refrigerant	Type			-	R290	R290				
	Factory Charging			g	630	870				
				tCO ₂ e	0.00189	0.00255				
	Control Method			-	EEV	EEV				
Outdoor Unit	Compressor	Type			-	Rotary	Rotary			
		Model Name			-	UF8HC5180FEU	UF5HC5260FEX			
		Oil	Type		-	Mineral	Mineral			
			Initial Charge		cc	590	850			
		Quantity			EA	1	1			
		Output			W	1,551	2,236			
		Starting method			-	Inverter driven	Inverter driven			
		Motor	Crankcase heater	Output	W	-	-			

2. Outdoor Units

2-1. Specifications

Model Name		Indoor Unit		AE200CNWMEG/EU	AE200CNWMEG/EU	
		Outdoor Unit		AE050CXDEK/EU	AE080CXDEK/EU	
Outdoor Unit	Heat exchanger	Length		mm	986/957	986/957/928
		Rows	Quantity	EA	2	3
		Fin pitch		mm	1.5	1.5
		Passes	Quantity	EA	6-6	9-9
		Face area		m ²	0.79	0.79
		Stages	Quantity	EA	38	38
		Empty tubeplate hole	Quantity	EA	-	-
		Tube type		-	Φ7	Φ7
		Fin	Type	-	Corrugate	Corrugate
			Treatment	-	Anti Salt	Anti Salt
	Fan	Type		-	Propeller Fan	Propeller Fan
		Discharge direction		-	Horizontal	Horizontal
		Air Flow Rate	Heating	m ³ /min	52	65
			Cooling	m ³ /min	55	69
		Quantity	EA	1	1	
	Fan motor	Quantity		EA	1	1
		Model		-	FMDC531SSJ	FMDC531SSJ
		Output		W	125	125
		Drive		-	Direct drive	Direct drive
		Speed	Steps	-	-	-
			Heating	rpm	550	720
	Cooling		rpm	580	760	
	Sound Level	Sound Pressure Level	Heating	dB(A)	41	45
			Cooling	dB(A)	41	45
			Night Mode(3m)	dB(A)	35	35
		Sound Power Level	Heating	dB(A)	55	59
	Cooling		dB(A)	55	59	
	Connections	Water pipe	Inlet	-	BSPP male 1"	BSPP male 1"
			Outlet	-	BSPP male 1"	BSPP male 1"
	Casing	Color	-	Shadow Gray	Shadow Gray	
		Material	-	GI-SGCC	GI-SGCC	
	Packing	Material	-	EPS/BOX	EPS/BOX	
		Weight	kg	13	13	
	External Dimension	Net Weight		kg	86	98
		Shipping Weight		kg	96	108
		Net Dimensions (WxHxD)		mm	998x850x500	998x850x500
Shipping Dimensions (WxHxD)		mm	1,070x1,018x630	1,070x1,018x630		
Operating Temp. Range	Heating	Min.	°C	-25	-25	
		Max.	°C	35	35	
	Cooling	Min.	°C	10	10	
		Max.	°C	46	46	
	D.Hot Water	Min.	°C	-25	-25	
		Max.	°C	43	43	

NOTE

- Specifications may be subject to change without prior notice.
- 1) A2W Condition #1 : (Heating) Water In/Out 30°C/35°C, Outdoor Air 7°C[DB]/6°C[WB];
(Cooling) Water In/Out 23°C/18°C, Outdoor Air 35°C[DB].
- 2) A2W Condition #2 : (Heating) Water In/Out 40°C/45°C, Outdoor Air 7°C[DB]/6°C[WB];
(Cooling) Water In/Out 12°C/7°C, Outdoor Air 35°C[DB].
- 3) A2W Condition #3 : (Heating) Water In/Out 47°C/55°C, Outdoor Air 7°C[DB]/6°C[WB].
- 4) A2W Condition : (A2W35) Water In/Out -/35°C, Outdoor Air 2°C[DB]/1°C[WB];
(A-7/W35) Water In/Out -/35°C, Outdoor Air -7°C[DB]/-(※ Peak Capacity)
- 5) Select wire size based on the value of MCA.
- 6) Soundpressure level is obtained in an anechoic room.
 - Sound pressure level is a relative value, depending on the distance and acoustic environment.
 - Sound pressure level may differ depending on operation condition.
 - dBA = A-weighted sound pressure level
 - Reference acoustic pressure 0 dB = 20uPa
- 7) Sound power level is an absolute value that a sound source generates.
 - dBA = A-weighted Sound power level
 - Reference power : 1pW
 - Measured according to ISO 3741
- 8) These products contain R290 (GWP=3) which is fluorinated greenhouse gas.
- 9) The system is operated in (-25°C ≤ Outdoor temp. < -20°C) condition, but no guarantee of capacity.
- 10) The system is operated by only Booster Heater in special condition (35 °C < Outdoor temp. ≤ 43°C).

2. Outdoor Units

2-1. Specifications

Model Name		Indoor Unit			AE200CNWMEG/EU	AE200CNWMEG/EU	AE260CNWMEG/EU	
		Outdoor Unit			AE120CXUDEK/EU	AE160CXUDEK/EU	AE080CXUDEK/EU	
Power Supply				Φ, #, V, Hz	1, 2, 220~240, 50	1, 2, 220~240, 50	1, 2, 220~240, 50	
System	Mode			-	Heat Pump (A2W)	Heat Pump (A2W)	Heat Pump (A2W)	
	Performance	Capacity	Heating	A2W Condition #1. (A7/W35) ^{1)*}	W	12,000	16,000	8,000
				Btu/h	40,900	54,600	27,300	
				A2W condition #2	W	12,000	16,000	8,000
				A2W condition #3		12,000	16,000	8,000
				A2/W35 ^{4)*}		12,000	16,000	8,000
			A-7/W35 ^{4)*}	12,000	16,000	8,000		
			Cooling	A2W Condition #1. (A35/W18) ^{1)*}	W	12,000	14,000	8,000
				Btu/h	40,900	47,800	27,300	
				A2W condition #2	W	9,000	10,400	5,700
				Power Input			W	2,500
	Heating	A2W condition #2		3,240	4,570	2,160		
		A2W condition #3	4,000	5,520	2,670			
		A2/W35 ^{4)*}	2,790	4,100	1,900			
		A-7/W35 ^{4)*}	4,000	5,710	2,670			
	Cooling	A2W Condition #1. (A35/W18) ^{1)*}	W	3,000	3,680	2,050		
		A2W condition #2	3,103	3,586	1,900			
	Current Input	Heating	A2W Condition #1.	A	11.81	16.78	7.70	
					14.18	17.39	9.69	
		Cooling	A2W condition #2	A	15.31	21.60	10.21	
					18.90	26.09	12.62	
		Current	MCA	A	32.0	32.0	26.0	
	MFA		A	35.2	35.2	28.6		
	Efficiency	COP (Nominal Heating) A2W condition #1			4.80	4.51	4.91	
		EER (Nominal Cooling) A2W condition #1			4.00	3.80	3.90	
		EER (Nominal Cooling) A2W condition #2			2.90	2.90	3.00	
		COP		A2W condition #2	W/W	3.70	3.50	3.70
				A2W condition #3		3.00	2.90	3.00
				A2/W35 ^{4)*}		4.30	3.90	4.20
				A-7/W35 ^{4)*}		3.00	2.80	3.00
		PdesignH (LWT 35°C)			12,000	15,500	8,000	
		PdesignH (LWT 55°C)			12,000	14,500	8,000	
		SCOP (35°C)			4.90	4.70	4.85	
		SCOP (55°C)			3.65	3.55	3.55	
		SCOP Class (35°C)			A+++	A+++	A+++	
		SCOP Class (55°C)			A++	A++	A++	
		SEER			4.80	5.00	4.30	
		Water Connections	Water Flow Rate (Nominal)		Heating	LPM	34.6	46.2
			Cooling	LPM	34.6	40.4	21.6	
	Water Flow Rate		Min	LPM	7	7	7	
			Max	LPM	58	58	48	
Water Pressure (Max)				bar	3	3	3	
Water Pipe Type	threaded male		Inlet	Φ, mm	28	28	28	
			Outlet	Φ, mm	28	28	28	
Leaving Water Temperature	Min.		Heating	°C	15	15	15	
				°C	75	75	75	
	Max.		Cooling	°C	5	5	5	
		°C		25	25	25		
Refrigerant	Type			-	R290	R290	R290	
	Factory Charging			g	1,250	1,250	870	
				tCO ₂ e	0.00375	0.00375	0.00255	
	Control Method			-	EEV	EEV	EEV	
Outdoor Unit	Compressor	Type			-	Scroll	Scroll	Rotary
		Model Name			-	DS4HC5066FNA	DS4HC5066FNA	UF5HC5260FEX
		Oil	Type		-	Kixx RF P85	Kixx RF P85	Mineral
			Initial Charge		cc	1,100	1,100	850
		Quantity			EA	1	1	1
		Output			W	3,803	3,803	2,236
		Starting method			-	Inverter driven	Inverter driven	Inverter driven
		Motor	Crankcase heater	Output	W	-	-	-

2. Outdoor Units

2-1. Specifications

Model Name		Indoor Unit		AE200CNWMEG/EU	AE200CNWMEG/EU	AE260CNWMEG/EU	
		Outdoor Unit		AE120CXYDEK/EU	AE160CXYDEK/EU	AE080CXYDEK/EU	
Outdoor Unit	Heat exchanger	Length		mm	1,239/1,210/1,182	1,239/1,210/1,182	986/957/928
		Rows	Quantity	EA	3	3	3
		Fin pitch		mm	1.5	1.5	1.5
		Passes	Quantity	EA	22-12	22-12	9-9
		Face area		m ²	1.17	1.17	0.79
		Stages	Quantity	EA	46	46	38
		Empty tubeplate hole	Quantity	EA	-	-	-
		Tube type		-	Φ7	Φ7	Φ7
		Fin	Type	-	Corrugate	Corrugate	Corrugate
			Treatment	-	Anti Salt	Anti Salt	Anti Salt
	Fan	Type		-	Propeller Fan	Propeller Fan	Propeller Fan
		Discharge direction		-	Horizontal	Horizontal	Horizontal
		Air Flow Rate	Heating	m ³ /min	95	95	65
			Cooling	m ³ /min	90	90	69
		Quantity	EA	1	1	1	
	Fan motor	Quantity	EA	1	1	1	
		Model	-	SIC-88FWJ-F1122-1	SIC-88FWJ-F1122-1	FMDC531SSJ	
		Output	W	122	122	125	
		Drive	-	Direct drive	Direct drive	Direct drive	
		Speed	Steps	-	-	-	-
			Heating	rpm	590	590	720
	Cooling		rpm	560	580	760	
	Sound	Sound Pressure	Heating	dB(A)	47	51	45
			Cooling	dB(A)	47	51	45
			Night Mode(3m)	dB(A)	35	35	35
		Sound Power	Heating	dB(A)	60	65	59
	Cooling		dB(A)	60	65	59	
	Connections	Water pipe	inlet	-	BSPP male 1"	BSPP male 1"	BSPP male 1"
			outlet	-	BSPP male 1"	BSPP male 1"	BSPP male 1"
	Casing	Color	-	Shadow Gray	Shadow Gray	Shadow Gray	
		Material	-	GI-SGCC	GI-SGCC	GI-SGCC	
	Packing	Material	-	EPS/BOX	EPS/BOX	EPS/BOX	
		Weight	kg	20	20	13	
	External Dimension	Net Weight		kg	140	140	98
		Shipping Weight		kg	154	154	108
		Net Dimensions (WxHxD)		mm	1,270x1,018x530	1,270x1,018x530	998x850x500
		Shipping Dimensions (WxHxD)		mm	1,330x1,226x630	1,330x1,226x630	1,070x1,028x630
	Operating Temp. Range	Heating	Min.	°C	-25	-25	-25
			Max.	°C	35	35	35
		Cooling	Min.	°C	10	10	10
Max.			°C	46	46	46	
D.Hot Water		Min.	°C	-25	-25	-25	
		Max.	°C	43	43	43	

NOTE

- Specifications may be subject to change without prior notice.
- 1) A2W Condition #1 : (Heating) Water In/Out 30°C/35°C, Outdoor Air 7°C[DB]/6°C[WB]; (Cooling) Water In/Out 23°C/18°C, Outdoor Air 35°C[DB].
- 2) A2W Condition #2 : (Heating) Water In/Out 40°C/45°C, Outdoor Air 7°C[DB]/6°C[WB]; (Cooling) Water In/Out 12°C/7°C, Outdoor Air 35°C[DB].
- 3) A2W Condition #3 : (Heating) Water In/Out 47°C/55°C, Outdoor Air 7°C[DB]/6°C[WB].
- 4) A2W Condition : (A2W35) Water In/Out -/35°C, Outdoor Air 2°C[DB]/1°C[WB]; (A-7/W35) Water In/Out -/35°C, Outdoor Air -7°C[DB]/-(※ Peak Capacity)
- 5) Select wire size based on the value of MCA.
- 6) Soundpressure level is obtained in an anechoic room.
 - Sound pressure level is a relative value, depending on the distance and acoustic environment.
 - Sound pressure level may differ depending on operation condition.
 - dBA = A-weighted sound pressure level
 - Reference acoustic pressure 0 dB = 20uPa
- 7) Sound power level is an absolute value that a sound source generates.
 - dBA = A-weighted Sound power level
 - Reference power : 1pW
 - Measured according to ISO 3741
- 8) These products contain R290 (GWP=3) which is fluorinated greenhouse gas.
- 9) The system is operated in (-25°C ≤ Outdoor temp. < -20°C) condition, but no guarantee of capacity.
- 10) The system is operated by only Booster Heater in special condition (35 °C < Outdoor temp. ≤ 43°C).

2. Outdoor Units

2-1. Specifications

Model Name		Indoor Unit			AE260CNWMEG/EU		AE260CNWMEG/EU			
		Outdoor Unit			AE120CXYDEK/EU		AE160CXYDEK/EU			
Power Supply				Φ, #, V, Hz	1, 2, 220~240, 50	1, 2, 220~240, 50				
System	Mode			-	Heat Pump (A2W)		Heat Pump (A2W)			
	Performance	Capacity	Heating	A2W Condition #1. (A7/W35) ^{1)*}	W	12,000	16,000			
				A2W condition #2	Btu/h	40,900	54,600			
				A2W condition #3	W	12,000	16,000			
				A2/W35 ^{4)*}		12,000	16,000			
				A-7/W35 ^{4)*}		12,000	16,000			
			Cooling	A2W Condition #1. (A35/W18) ^{1)*}	W	12,000	14,000			
				A2W condition #2	Btu/h	40,900	47,800			
							W	9,000	10,400	
							W	2,500	3,550	
							W	3,240	4,570	
	Power	Power Input	Heating	A2W Condition #1. (A7/W35) ^{1)*}	W	4,000	5,520			
				A2W condition #2		2,790	4,100			
				A2/W35 ^{4)*}		4,000	5,710			
				A-7/W35 ^{4)*}						
							W	3,000	3,680	
			Cooling	A2W Condition #1. (A35/W18) ^{1)*}	W	3,103	3,586			
				A2W condition #2		11.81	16.78			
							A	14.18	17.39	
			Current Input	Heating	A2W Condition #1.	A	15.31	21.60		
							18.90	26.09		
							A	32.0	32.0	
	Current	MCA				35.2	35.2			
		MFA				35.2	35.2			
	Efficiency	COP (Nominal Heating) A2W condition #1				4.80	4.51			
		EER (Nominal Cooling) A2W condition #1				4.00	3.80			
		EER (Nominal Cooling) A2W condition #2				2.90	2.90			
		COP			A2W condition #2	W/W	3.70	3.50		
					A2W condition #3		3.00	2.90		
					A2/W35 ^{4)*}		4.30	3.90		
					A-7/W35 ^{4)*}		3.00	2.80		
					PdesignH (LWT 35°C)				12,000	15,500
		PdesignH (LWT 55°C)				12,000	14,500			
		SCOP (35°C)				4.90	4.70			
		SCOP (55°C)				3.65	3.55			
		SCOP Class (35°C)				A+++	A+++			
		SCOP Class (55°C)				A++	A++			
		SEER				4.80	5.00			
		Water Connections	Water Flow Rate (Nominal)		Heating	LPM	34.6	46.2		
			Cooling	LPM	34.6	40.4				
	Water Flow Rate		Min	LPM	7	7				
			Max	LPM	58	58				
	Water Pressure (Max)				bar	3	3			
	Water Pipe Type		threaded male	Inlet	Φ, mm	28	28			
				Outlet	Φ, mm	28	28			
	Leaving Water Temperature		Min.	Heating	°C	15	15			
					°C	75	75			
			Max.	Cooling	°C	5	5			
		°C			25	25				
	Refrigerant	Type			-	R290	R290			
Factory Charging			g	1,250	1,250					
			tCO ₂ e	0.00375	0.00375					
Control Method			-	EEV	EEV					
Outdoor Unit	Compressor	Type			-	Scroll	Scroll			
		Model Name			-	DS4HC5066FNA	DS4HC5066FNA			
		Oil	Type		-	Kixx RF P85	Kixx RF P85			
			Initial Charge		cc	1,100	1,100			
		Quantity			EA	1	1			
		Output			W	3,803	3,803			
		Starting method			-	Inverter driven	Inverter driven			
Motor	Crankcase heater	Output	W	-	-					

2. Outdoor Units

2-1. Specifications

Model Name		Indoor Unit		AE260CNWMEG/EU	AE260CNWMEG/EU	
		Outdoor Unit		AE120CXYDEK/EU	AE160CXYDEK/EU	
Outdoor Unit	Heat exchanger	Length		mm	1,239/1,210/1,182	1,239/1,210/1,182
		Rows	Quantity	EA	3	3
		Fin pitch		mm	1.5	1.5
		Passes	Quantity	EA	22-12	22-12
		Face area		m ²	1.17	1.17
		Stages	Quantity	EA	46	46
		Empty tubeplate hole	Quantity	EA	-	-
		Tube type		-	Φ7	Φ7
		Fin	Type	-	Corrugate	Corrugate
			Treatment	-	Anti Salt	Anti Salt
	Fan	Type		-	Propeller Fan	Propeller Fan
		Discharge direction		-	Horizontal	Horizontal
		Air Flow Rate	Heating	m ³ /min	95	95
			Cooling	m ³ /min	90	94
		Quantity		EA	1	1
	Fan motor	Quantity		EA	1	1
		Model		-	SIC-88FWJ-F1122-1	SIC-88FWJ-F1122-1
		Output		W	122	122
		Drive		-	Direct drive	Direct drive
		Speed	Steps	-	-	-
			Heating	rpm	590	590
	Cooling		rpm	560	580	
	Sound Level	Sound Pressure Level	Heating	dB(A)	47	51
			Cooling	dB(A)	47	51
			Night Mode(3m)	dB(A)	35	35
		Sound Power Level	Heating	dB(A)	60	65
	Cooling		dB(A)	60	65	
	Connections	Water pipe	Inlet	-	BSPP male 1"	BSPP male 1"
			Outlet	-	BSPP male 1"	BSPP male 1"
	Casing	Color	-	Shadow Gray	Shadow Gray	
		Material	-	GI-SGCC	GI-SGCC	
	Packing	Material	-	EPS/BOX	EPS/BOX	
		Weight	kg	20	20	
	External Dimension	Net Weight		kg	140	140
		Shipping Weight		kg	154	154
		Net Dimensions (WxHxD)		mm	1,270x1,018x530	1,270x1,018x530
		Shipping Dimensions (WxHxD)		mm	1,330x1,226x630	1,330x1,226x630
	Operating Temp. Range	Heating	Min.	°C	-25	-25
			Max.	°C	35	35
		Cooling	Min.	°C	10	10
Max.			°C	46	46	
D.Hot Water		Min.	°C	-25	-25	
		Max.	°C	43	43	

NOTE

- Specifications may be subject to change without prior notice.
- 1) A2W Condition #1 : (Heating) Water In/Out 30°C/35°C, Outdoor Air 7°C[DB]/6°C[WB];
(Cooling) Water In/Out 23°C/18°C, Outdoor Air 35°C[DB].
- 2) A2W Condition #2 : (Heating) Water In/Out 40°C/45°C, Outdoor Air 7°C[DB]/6°C[WB];
(Cooling) Water In/Out 12°C/7°C, Outdoor Air 35°C[DB].
- 3) A2W Condition #3 : (Heating) Water In/Out 47°C/55°C, Outdoor Air 7°C[DB]/6°C[WB].
- 4) A2W Condition : (A2W35) Water In/Out -/35°C, Outdoor Air 2°C[DB]/1°C[WB];
(A-7/W35) Water In/Out -/35°C, Outdoor Air -7°C[DB]/-(* Peak Capacity)
- 5) Select wire size based on the value of MCA.
- 6) Soundpressure level is obtained in an anechoic room.
 - Sound pressure level is a relative value, depending on the distance and acoustic environment.
 - Sound pressure level may differ depending on operation condition.
 - dBA = A-weighted sound pressure level
 - Reference acoustic pressure 0 dB = 20uPa
- 7) Sound power level is an absolute value that a sound source generates.
 - dBA = A-weighted Sound power level
 - Reference power : 1pW
 - Measured according to ISO 3741
- 8) These products contain R290 (GWP=3) which is fluorinated greenhouse gas.
- 9) The system is operated in (-25°C ≤ Outdoor temp. < -20°C) condition, but no guarantee of capacity.
- 10) The system is operated by only Booster Heater in special condition (35 °C < Outdoor temp. ≤ 43°C).

2. Outdoor Units

2-1. Specifications

Model Name		Indoor Unit			AE260CNWMGG/EU	AE260CNWMGG/EU	AE260CNWMGG/EU		
		Outdoor Unit			AE080CXYDGK/EU	AE120CXYDGK/EU	AE160CXYDGK/EU		
Power Supply				Φ, #, V, Hz	3, 4, 380~415, 50	3, 4, 380~415, 50	3, 4, 380~415, 50		
System	Mode			-	Heat Pump (A2W)	Heat Pump (A2W)	Heat Pump (A2W)		
	Performance	Capacity	Heating	A2W Condition #1. (A7/W35) ^{1)*}	W	8,000	12,000	16,000	
				Btu/h	27,300	40,900	54,600		
				A2W condition #2	W	8,000	12,000	16,000	
				A2W condition #3		8,000	12,000	16,000	
				A2/W35 ^{4)*}		8,000	12,000	16,000	
			A-7/W35 ^{4)*}	8,000	12,000	16,000			
			Cooling	A2W Condition #1. (A35/W18) ^{1)*}	W	8,000	12,000	14,000	
				Btu/h	27,300	40,900	47,800		
				A2W condition #2	W	5,700	9,000	10,400	
			Power	Power Input	Heating	A2W Condition #1. (A7/W35) ^{1)*}	W	1,630	2,500
	A2W condition #2	2,160				3,240		4,570	
	A2W condition #3	2,670				4,000		5,520	
	A2/W35 ^{4)*}	1,900				2,790		4,100	
	A-7/W35 ^{4)*}	2,670				4,000		5,710	
	Cooling	A2W Condition #1. (A35/W18) ^{1)*}			W	2,050	3,000	3,680	
		A2W condition #2				1,900	3,103	3,714	
		Current Input				Heating	A2W Condition #1.	A	2.56
	Cooling	A2W condition #2			3.22	4.71	5.77		
	Heating	A2W condition #2			A	3.39	5.08	7.17	
	Cooling			4.19		6.28	8.66		
	Current	MCA		A	16.1	16.1	16.1		
		MFA		A	17.7	17.7	17.7		
	Efficiency	COP (Nominal Heating) A2W condition #1				4.91	4.80	4.51	
		EER (Nominal Cooling) A2W condition #1				3.90	4.00	3.80	
		EER (Nominal Cooling) A2W condition #2				3.00	2.90	2.90	
		COP			A2W condition #2	W/W	3.70	3.70	3.50
					A2W condition #3		3.00	3.00	2.90
			A2/W35 ^{4)*}		4.20		4.30	3.90	
			A-7/W35 ^{4)*}		3.00		3.00	2.80	
		PdesignH (LWT 35°C)				8,000	12,000	15,500	
		PdesignH (LWT 55°C)				8,000	12,000	15,500	
		SCOP (35°C)				4.85	4.90	4.70	
		SCOP (55°C)				3.55	3.65	3.55	
		SCOP Class (35°C)				A+++	A+++	A+++	
		SCOP Class (55°C)				A++	A++	A++	
	SEER				4.30	4.80	5.00		
	Water Connections	Water Flow Rate (Nominal)		Heating	LPM	23.1	34.6	46.2	
				Cooling	LPM	21.6	34.6	40.4	
		Water Flow Rate		Min	LPM	7	7	7	
		Max	LPM	48	58	58			
Water Pressure (Max)			bar	3	3	3			
Water Pipe Type		threaded male	Inlet	Φ, mm	28	28	28		
			Outlet	Φ, mm	28	28	28		
Leaving Water Temperature		Min.	Heating	°C	15	15	15		
				°C	75	75	75		
		Max.	Cooling	°C	5	5	5		
	°C			25	25	25			
Refrigerant	Type			-	R290	R290	R290		
	Factory Charging			g	870	1,250	1,250		
				tCO ₂ e	0.00255	0.00375	0.00375		
	Control Method			-	EEV	EEV	EEV		
Outdoor Unit	Compressor	Type			-	Rotary	Scroll	Scroll	
		Model Name			-	UF5HC5260FEX	DS4HC5066FNA	DS4HC5066FNA	
		Oil	Type			-	Mineral	Kixx RF P85	Kixx RF P85
			Initial Charge			cc	850	1,100	1,100
		Quantity			EA	1	1	1	
		Output			W	2,236	3,803	3,803	
		Starting method			-	Inverter driven	Inverter driven	Inverter driven	
		Motor	Crankcase heater	Output	W	-	-	-	

2. Outdoor Units

2-1. Specifications

Model Name		Indoor Unit		AE260CNWMGG/EU	AE260CNWMGG/EU	AE260CNWMGG/EU	
		Outdoor Unit		AE080CXYDGK/EU	AE120CXYDGK/EU	AE160CXYDGK/EU	
Outdoor Unit	Heat exchanger	Length		mm	986/957/928	1,239/1,210/1,182	1,239/1,210/1,182
		Rows	Quantity	EA	3	3	3
		Fin pitch		mm	1.5	1.5	1.5
		Passes	Quantity	EA	9-9	22-12	22-12
		Face area		m ²	0.79	1.17	1.17
		Stages	Quantity	EA	38	46	46
		Empty tubeplate hole	Quantity	EA	-	-	-
		Tube type		-	Φ7	Φ7	Φ7
		Fin	Type	-	Corrugate	Corrugate	Corrugate
	Treatment		-	Anti Salt	Anti Salt	Anti Salt	
	Fan	Type		-	Propeller Fan	Propeller Fan	Propeller Fan
		Discharge direction		-	Horizontal	Horizontal	Horizontal
		Air Flow Rate	Heating	m ³ /min	65	95	95
			Cooling	m ³ /min	69	90	94
		Quantity		EA	1	1	1
	Fan motor	Quantity		EA	1	1	1
		Model		-	FMDC531SSJ	SIC-88FWJ-F1122-1	SIC-88FWJ-F1122-1
		Output		W	125	122	122
		Drive		-	Direct drive	Direct drive	Direct drive
		Speed	Steps	-	-	-	-
			Heating	rpm	720	590	590
	Cooling		rpm	760	560	580	
	Sound Level	Sound Pressure Level	Heating	dB(A)	45	47	51
			Cooling	dB(A)	45	47	51
			Night Mode(3m)	dB(A)	35	35	35
		Sound Power Level	Heating	dB(A)	59	60	65
	Cooling		dB(A)	59	60	65	
	Connections	Water pipe	Inlet	-	BSPP male 1"	BSPP male 1"	BSPP male 1"
			Outlet	-	BSPP male 1"	BSPP male 1"	BSPP male 1"
	Casing	Color	-	Shadow Gray	Shadow Gray	Shadow Gray	
		Material	-	GI-SGCC	GI-SGCC	GI-SGCC	
	Packing	Material	-	EPS/BOX	EPS/BOX	EPS/BOX	
		Weight	kg	13	20	20	
	External Dimension	Net Weight		kg	98	140	140
		Shipping Weight		kg	108	154	154
		Net Dimensions (WxHxD)		mm	998x850x500	1,270x1,018x530	1,270x1,018x530
		Shipping Dimensions (WxHxD)		mm	1,070x1,018x630	1,330x1,226x630	1,330x1,226x630
	Operating Temp. Range	Heating	Min.	°C	-25	-25	-25
			Max.	°C	35	35	35
		Cooling	Min.	°C	10	10	10
			Max.	°C	46	46	46
		D.Hot Water	Min.	°C	-25	-25	-25
			Max.	°C	43	43	43

NOTE

- Specifications may be subject to change without prior notice.
- 1) A2W Condition #1 : (Heating) Water In/Out 30°C/35°C, Outdoor Air 7°C[DB]/6°C[WB]; (Cooling) Water In/Out 23°C/18°C, Outdoor Air 35°C[DB].
- 2) A2W Condition #2 : (Heating) Water In/Out 40°C/45°C, Outdoor Air 7°C[DB]/6°C[WB]; (Cooling) Water In/Out 12°C/7°C, Outdoor Air 35°C[DB].
- 3) A2W Condition #3 : (Heating) Water In/Out 47°C/55°C, Outdoor Air 7°C[DB]/6°C[WB].
- 4) A2W Condition : (A2W35) Water In/Out -/35°C, Outdoor Air 2°C[DB]/1°C[WB]; (A-7/W35) Water In/Out -/35°C, Outdoor Air -7°C[DB]/-(※ Peak Capacity)
- 5) Select wire size based on the value of MCA.
- 6) Soundpressure level is obtained in an anechoic room.
 - Sound pressure level is a relative value, depending on the distance and acoustic environment.
 - Sound pressure level may differ depending on operation condition.
 - dBA = A-weighted sound pressure level
 - Reference acoustic pressure 0 dB = 20uPa
- 7) Sound power level is an absolute value that a sound source generates.
 - dBA = A-weighted Sound power level
 - Reference power : 1pW
 - Measured according to ISO 3741
- 8) These products contain R290 (GWP=3) which is fluorinated greenhouse gas.
- 9) The system is operated in (-25°C ≤ Outdoor temp. < -20°C) condition, but no guarantee of capacity.
- 10) The system is operated by only Booster Heater in special condition (35 °C < Outdoor temp. ≤ 43°C).

2. Outdoor Units

2-2. Electrical characteristics

Capacity [kW]	Model	Power Supply				Voltage Range [V]		Nominal Running Current [A]		Current [A]	
		Φ	#	Hz	Voltage	Min. (-10%)	Max. (+10%)	Cooling	Heating	MCA	MFA
5.0	AE050CXYDEK/EU	1	2	50	220-240	198	264	6.05	4.63	16.1	17.6
8.0	AE080CXYDEK/EU	1	2	50	220-240	198	264	9.69	7.70	26.0	28.6
12.0	AE120CXYDEK/EU	1	2	50	220-240	198	264	14.18	11.81	32.0	35.2
16.0	AE160CXYDEK/EU	1	2	50	220-240	198	264	17.39	16.78	32.0	35.2
8.0	AE080CXYDGK/EU	3	4	50	380-415	342	457	3.22	2.56	16.1	17.7
12.0	AE120CXYDGK/EU	3	4	50	380-415	342	457	4.71	3.92	16.1	17.7
16.0	AE160CXYDGK/EU	3	4	50	380-415	342	457	5.77	5.57	16.1	17.7

NOTE

- MCA : Minimum circuit amperes
- MFA : Maximum fuse amperes
- Select wire size based on the value of MCA

2. Outdoor Units

2-3. Dimensional drawing

AE050CXYDEK/EU, 080CXYD*K/EU

Units : mm [inches]

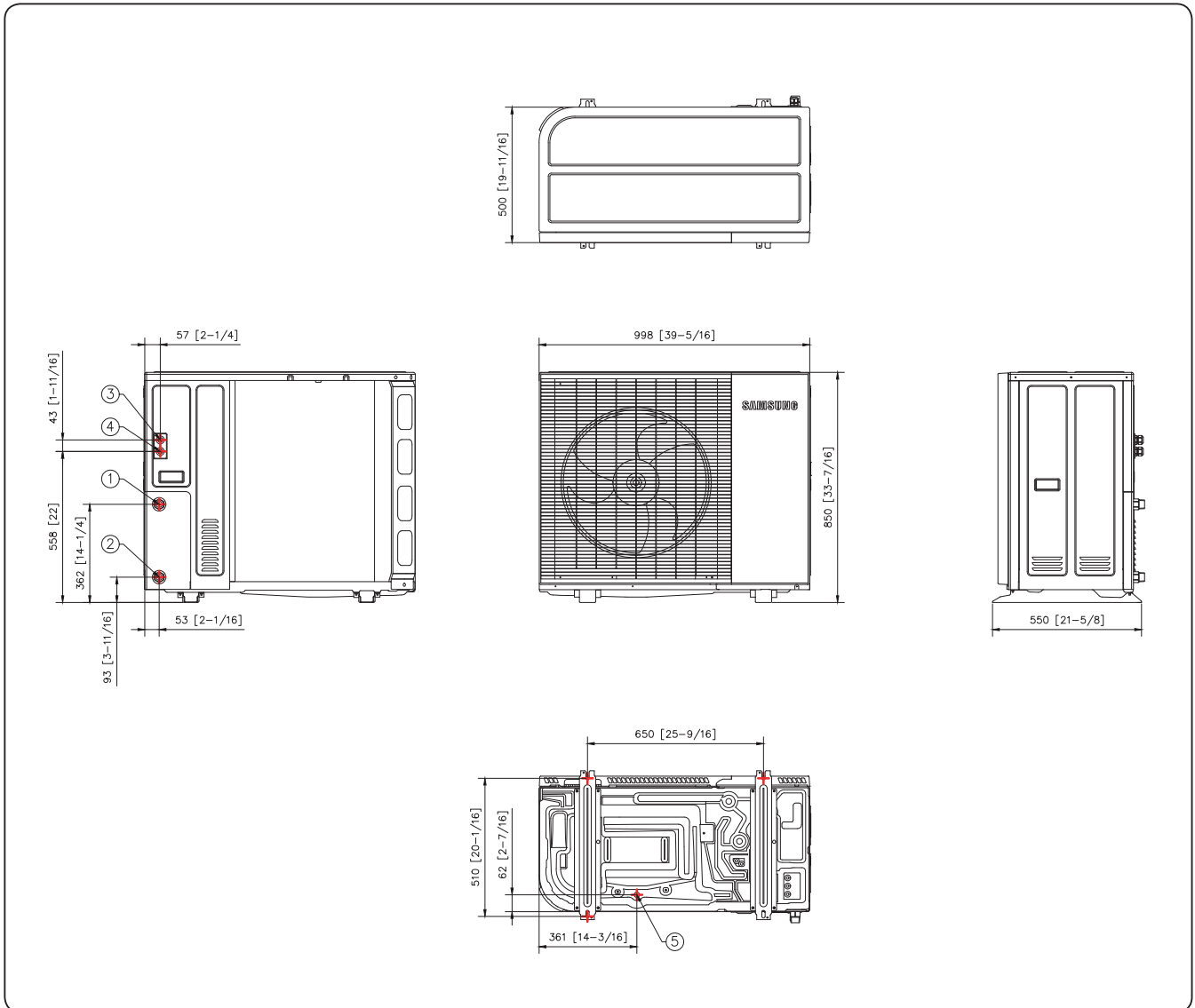

NO	Name	Description
1	Water Pipe(Out)	25A
2	Water Pipe(In)	25A
3	Power wiring conduit	M25x1.5 (Cable gland)
4	Communication wiring conduit	M25x1.5 (Cable gland)
5	Drain holes	∅20 (connect with the provided drain plug)

2. Outdoor Units

2-3. Dimensional drawing

AE120/160CXVD*K/EU

Units : mm [inches]

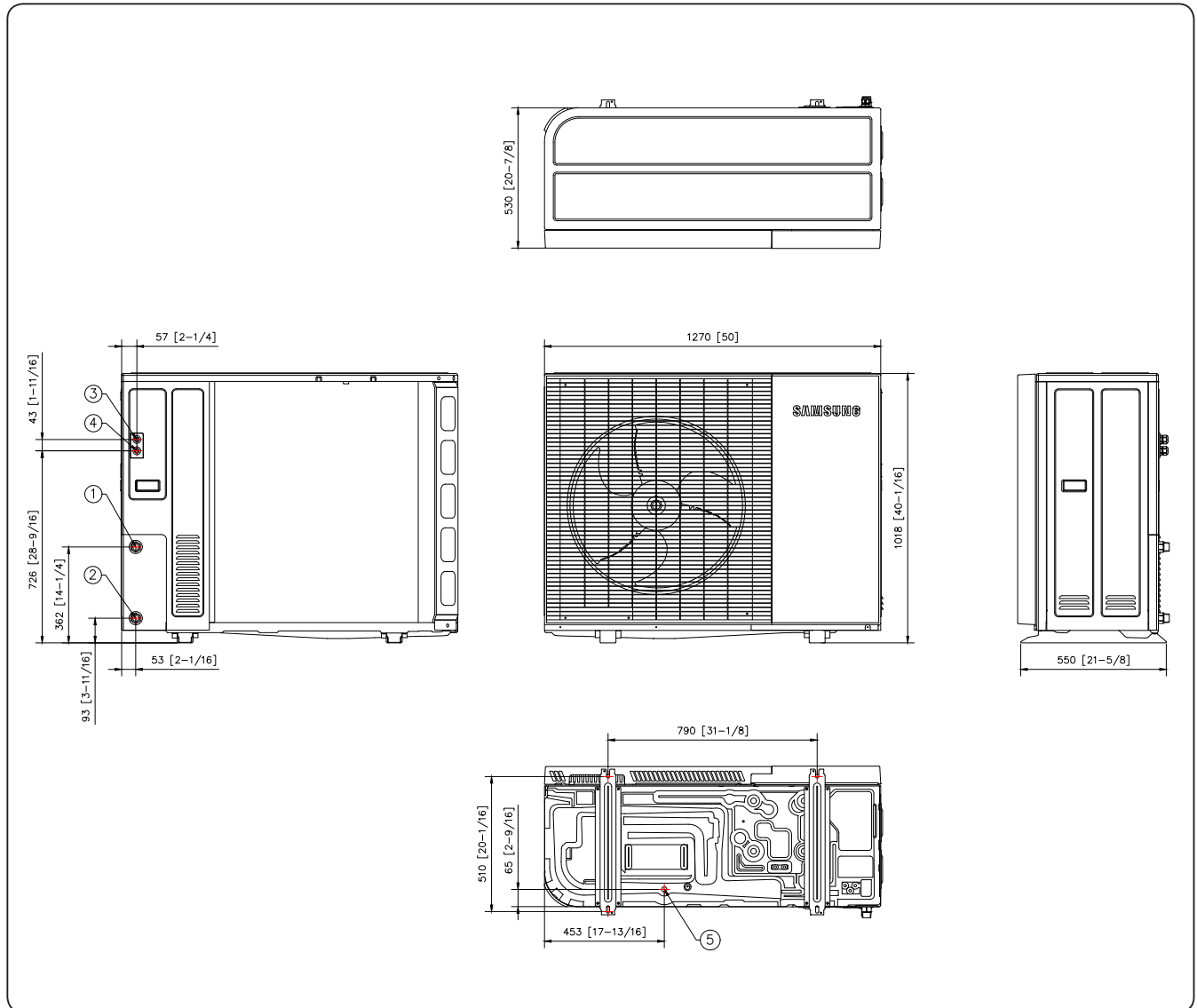

NO	Name	Description
1	Water Pipe(Out)	25A
2	Water Pipe(In)	25A
3	Power wiring conduit	M25x1.5 (Cable gland)
4	Communication wiring conduit	M25x1.5 (Cable gland)
5	Drain holes	∅20 (connect with the provided drain plug)

2. Outdoor Units

2-4. Center of Gravity

AE050CXYDEK/EU, 080CXYD*K/EU

Units : mm [inches]

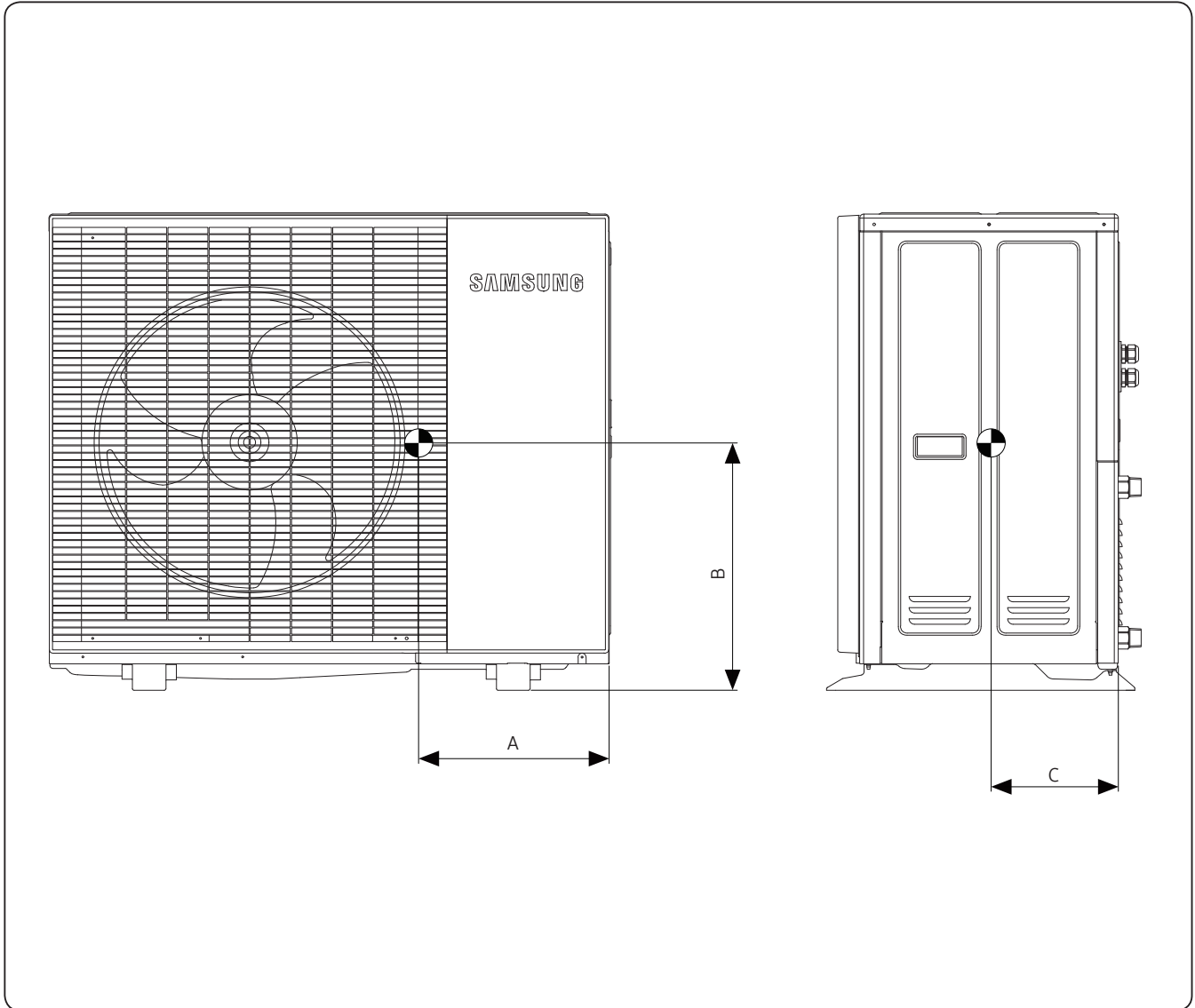

Model	A	B	C
AE050CXYDEK/EU AE080CXYDEK/EU AE080CXYDGK/EU	340 [13 3/8]	396 [15 9/16]	227 [8 15/16]

2. Outdoor Units

2-4. Center of Gravity

AE120/160CXVD*K/EU

Units : mm [inches]

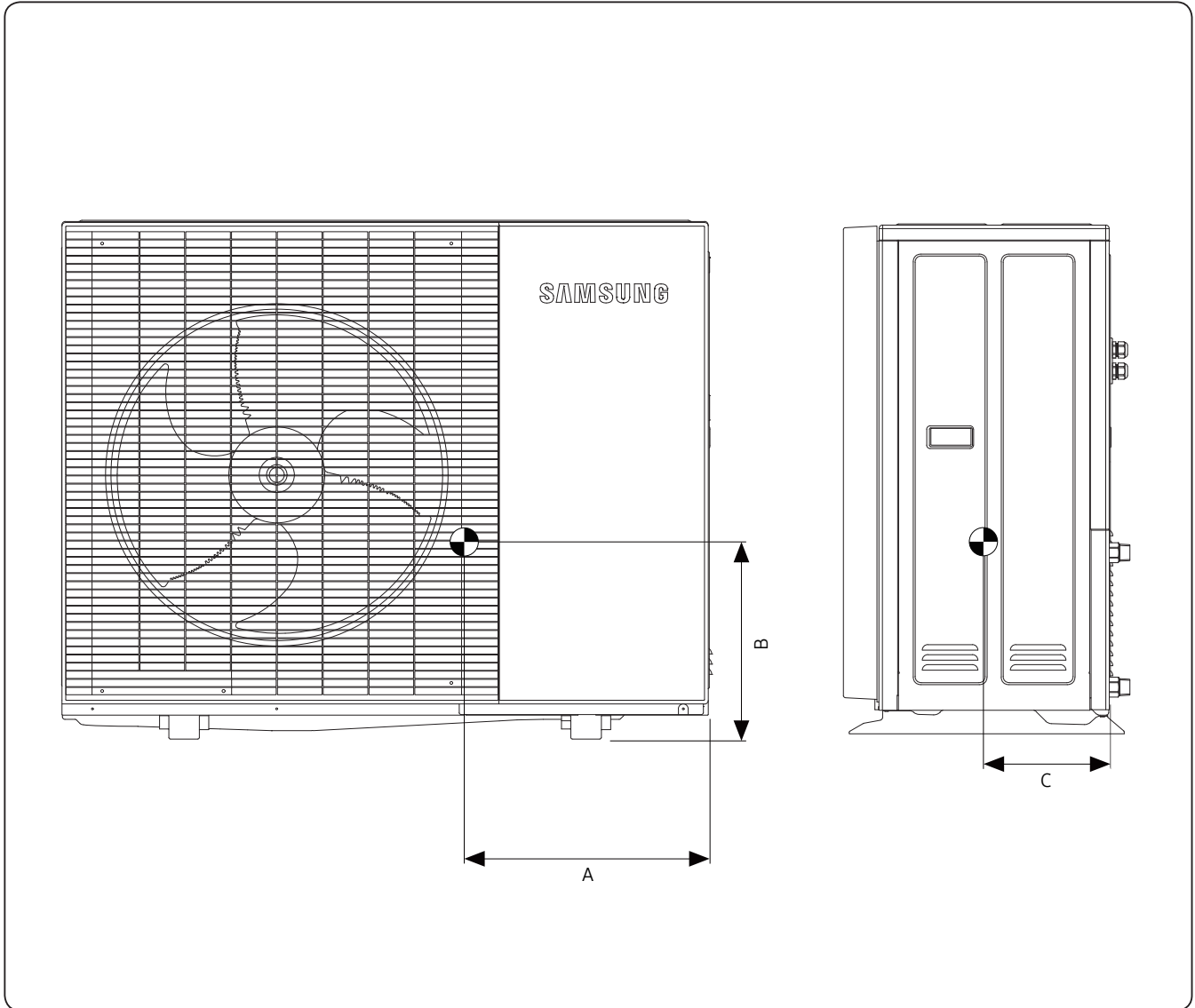

Model	A	B	C
AE120CXVD*K/EU AE160CXVD*K/EU	472 [18 9/16]	408 [16 1/16]	239 [9 7/16]

2. Outdoor Units

2-5. Electrical wiring diagram

AE050CXYDEK/EU, 080CXYD*K/EU

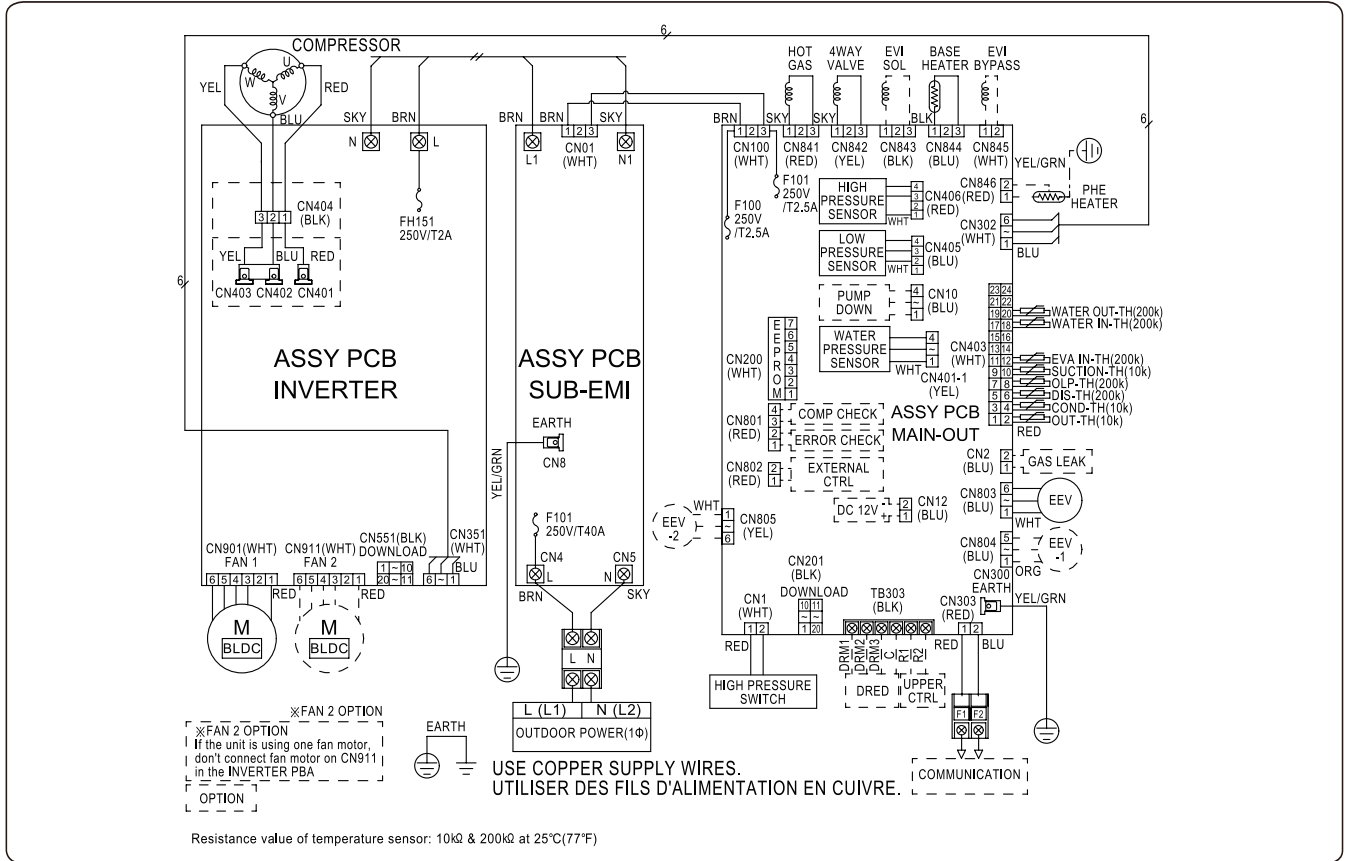

ASSY PCB MAIN-OUT	Printed circuit board(MAIN)	WATER OUT-TH(200k)	Thermistor (WATER OUT_200Kohm)
ASSY PCB INVER	Printed circuit board(INVERTER)	HOT GAS	Solenoid Valve - Hot Gas bypass
ASSY PCB SUB-EMI	Printed circuit board(EMI)	4WAY VALVE	Solenoid Valve - 4Way
OUT-TH(10k)	Thermistor (OUT_10Kohm)	EVI SOL	Solenoid Valve - EVI
COND-TH(10k)	Thermistor (COND_10Kohm)	EVI BYPASS	Solenoid Valve - EVI Bypass
DIS-TH(200k)	Thermistor (DISCHARGE_200Kohm)	M-BLDC	Motor for Outdoor Fan
OLP-TH(200k)	Thermistor (OLP_200Kohm)	EEV	Electronic Expansion Valve
SUCTON-TH(10k)	Thermistor (SUCTON_10kKohm)	EXTERNAL CTRL	External Control
EVA IN-TH(200k)	Thermistor (EVA IN_200Kohm)	UPPER CTRL	Upper Control
WATER IN-TH(200k)	Thermistor (WATER IN_200Kohm)		

NOTES

- This wiring diagram applies only to the Outdoor unit.
- Symbols show as follow :
BLK: black, RED: red, BLU: blue, WHT: white, YEL: yellow, BRN: brown, SKY: skyblue, GRN: green
- For connection wiring indoor-outdoor transmission F1-F2.
- ⊕ Protective earth(SCREW)

2. Outdoor Units

2-5. Electrical wiring diagram

AE120/160CX*YD*/K/EU

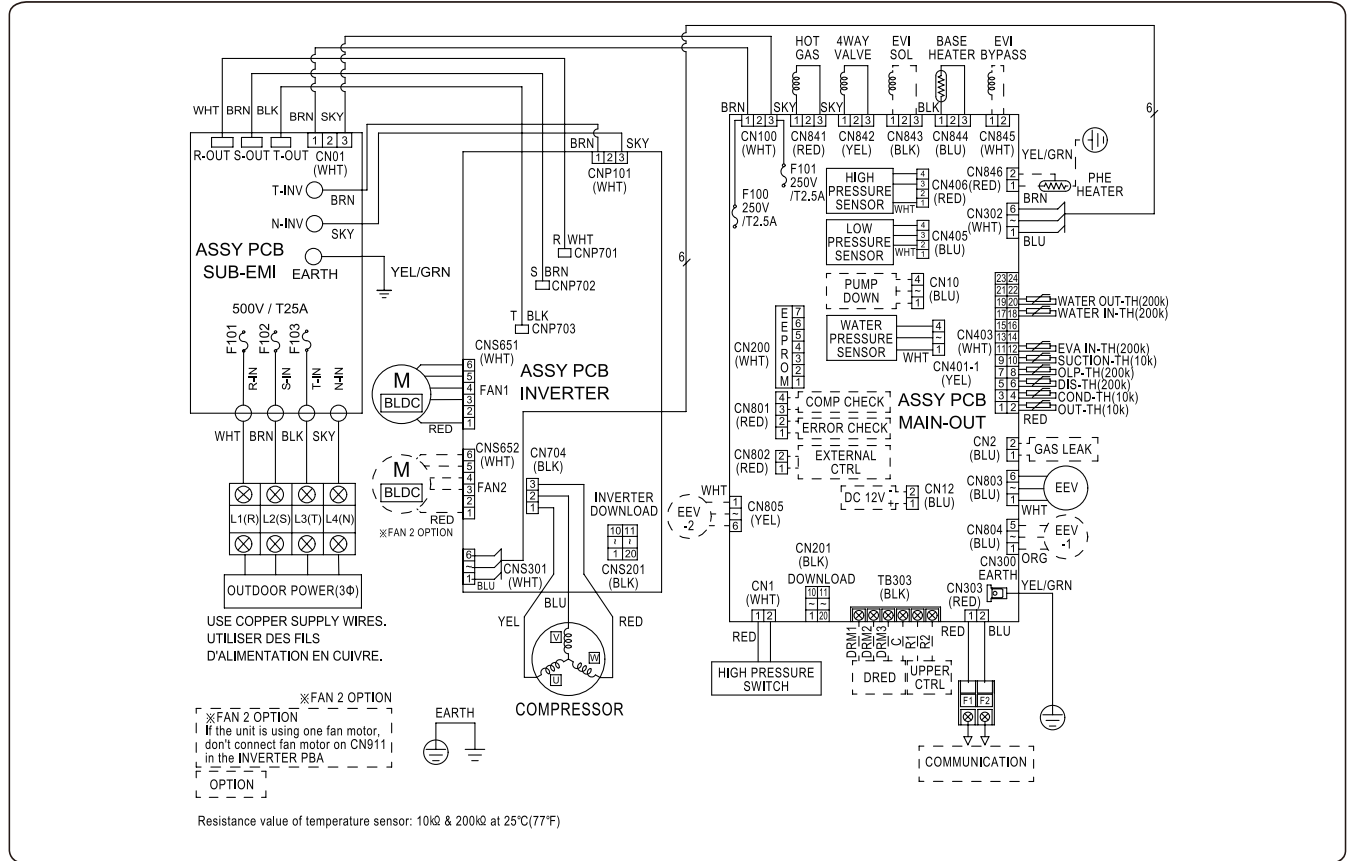

ASSY PCB MAIN-OUT	Printed circuit board(MAIN)	WATER OUT-TH(200k)	Thermistor (WATER OUT_200Kohm)
ASSY PCB INVER	Printed circuit board(INVERTER)	HOT GAS	Solenoid Valve - Hot Gas bypass
ASSY PCB SUB-EMI	Printed circuit board(EMI)	4WAY VALVE	Solenoid Valve - 4Way
OUT-TH(10k)	Thermistor (OUT_10Kohm)	EVI SOL	Solenoid Valve - EVI
COND-TH(10k)	Thermistor (COND_10Kohm)	EVI BYPASS	Solenoid Valve - EVI Bypass
DIS-TH(200k)	Thermistor (DISCHARGE_200Kohm)	M-BLDC	Motor for Outdoor Fan
OLP-TH(200k)	Thermistor (OLP_200Kohm)	EEV	Electronic Expansion Valve
SUCTION-TH(10k)	Thermistor (SUCTION_10kKohm)	EXTERNAL CTRL	External Control
EVA IN-TH(200k)	Thermistor (EVA IN_200Kohm)	UPPER CTRL	Upper Control
WATER IN-TH(200k)	Thermistor (WATER IN_200Kohm)		

NOTES

- This wiring diagram applies only to the Outdoor unit.
- Symbols show as follow :
BLK: black, RED: red, BLU: blue, WHT: white, YEL: yellow, BRN: brown, SKY: skyblue, GRN: green
- For connection wiring indoor-outdoor transmission F1-F2.
- ⊕ Protective earth(SCREW)

2. Outdoor Units

2-6. Sound data

Summary

Capacity (kW)	Model	Sound Pressure dB(A)		Sound Power dB(A)	
		Heating	Cooling	Heating	Cooling
5.0	AE050CXYDEK/EU	41	41	55	55
8.0	AE080CXYDEK/EU	45	45	59	59
12.0	AE120CXYDEK/EU	47	47	60	60
16.0	AE160CXYDEK/EU	51	51	65	65
8.0	AE080CXYDGK/EU	45	45	59	59
12.0	AE120CXYDGK/EU	47	47	60	60
16.0	AE160CXYDGK/EU	51	51	65	65

NOTE

- Specifications may be subject to change without prior notice.
- Sound Pressure Level
 - Sound pressure level is obtained in an anechoic room.
 - Sound pressure level is a relative value, depending on the distance and acoustic environment.
 - Sound pressure level may differ depending on operation condition.
 - dBA = A-weighted sound pressure level
 - Reference acoustic pressure 0 dB = 20μPa
- Sound Power Level
 - Sound power level is an absolute value that a sound source generates.
 - dBA = A-weighted sound power level.
 - Reference power : 1pW.
 - Measured according to ISO 3741.

2. Outdoor Units

2-6. Sound data

Sound Pressure level

Unit: dB(A)

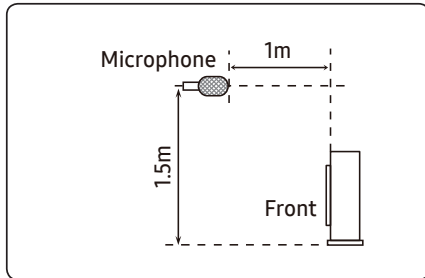

Model	Heating	Cooling
AE050CXYDEK/EU	41	41
AE080CXYDEK/EU	45	45
AE120CXYDEK/EU	47	47
AE160CXYDEK/EU	51	51

- NR Curve

1) AE050CXYDEK/EU

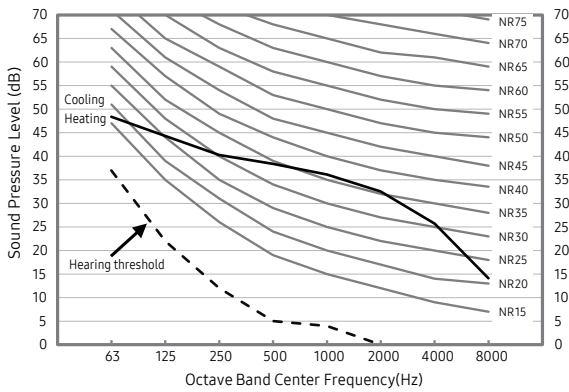

2) AE080CXYDEK/EU

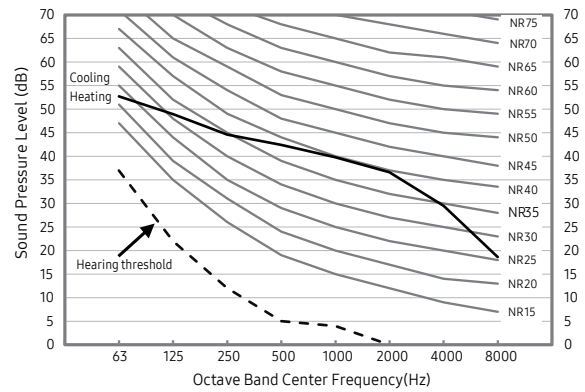

3) AE120CXYDEK/EU

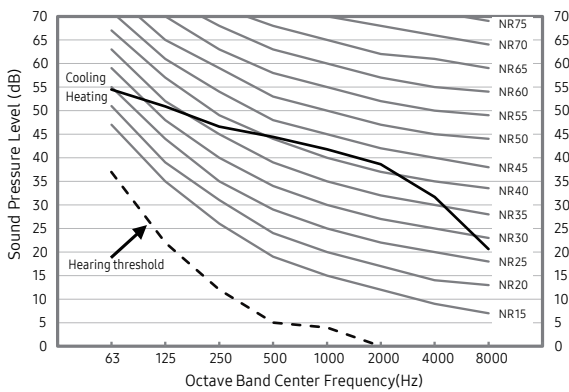

4) AE160CXYDEK/EU

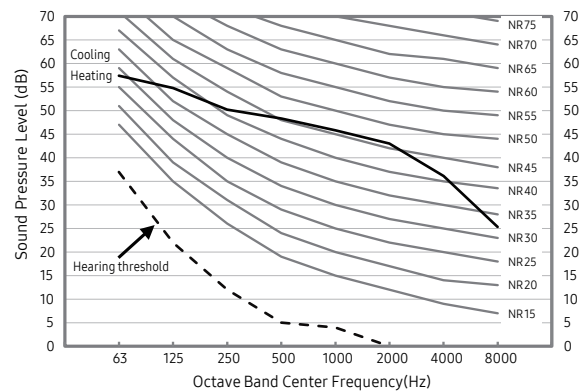

2. Outdoor Units

2-6. Sound data

Sound Pressure level

Unit: dB(A)

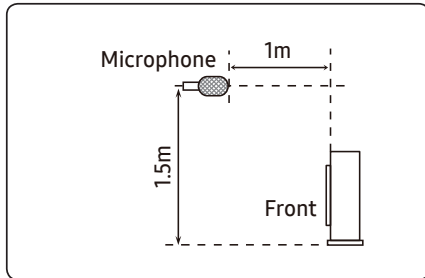

Model	Heating	Cooling
AE080CXYDGK/EU	45	45
AE120CXYDGK/EU	47	47
AE160CXYDGK/EU	51	51

- NR Curve

5) AE080CXYDGK/EU

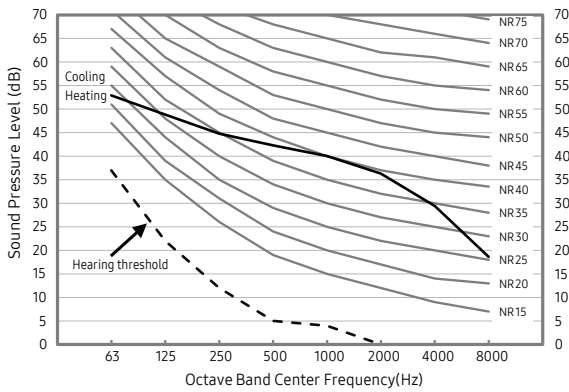

6) AE120CXYDGK/EU

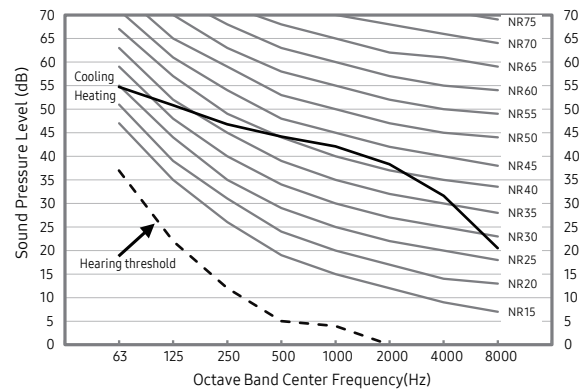

7) AE160CXYDGK/EU

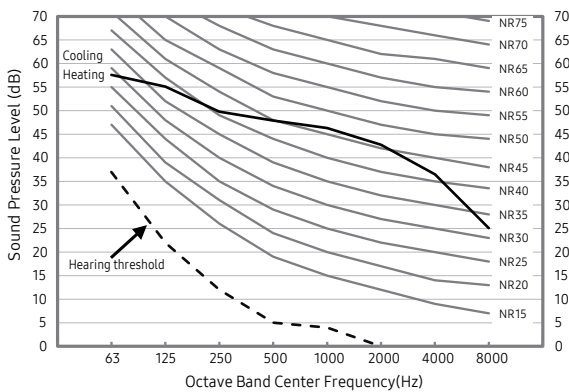

2. Outdoor Units

2-6. Sound data

Sound Power level

Unit: dB(A)

NOTE

- Specifications may be subject to change without prior notice
 - Sound power level is an absolute value that a sound source generates.
 - dBA = A-weighted sound power level.
 - Reference power : 1pW.
 - Measured according to ISO 3741.

Model	Heating	Cooling
AE050CXYDEK/EU	55	55
AE080CXYDEK/EU	59	59
AE120CXYDEK/EU	60	60
AE160CXYDEK/EU	65	65

• NR Curve

1) AE050CXYDEK/EU

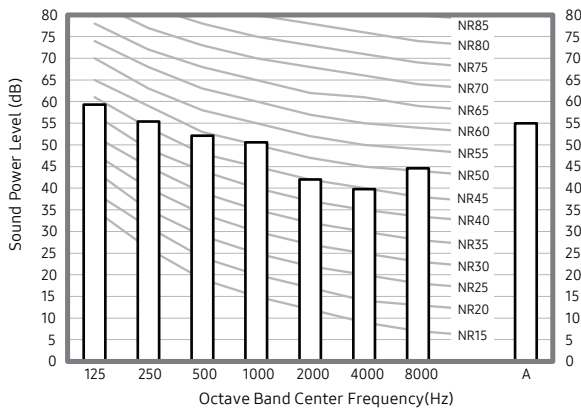

2) AE080CXYDEK/EU

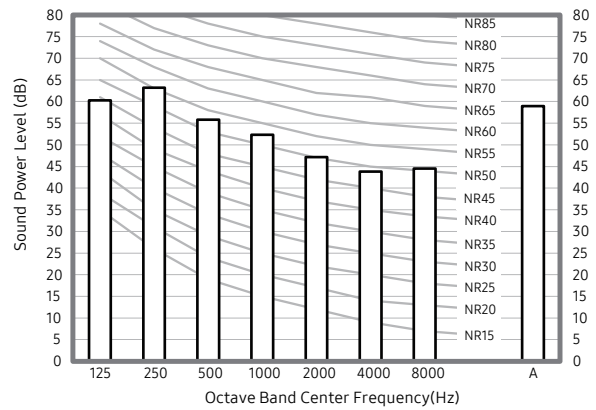

3) AE120CXYDEK/EU

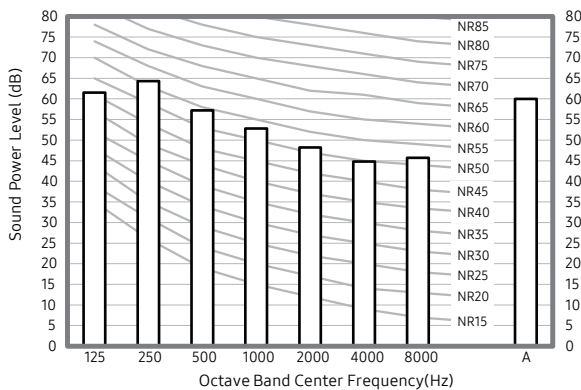

4) AE160CXYDEK/EU

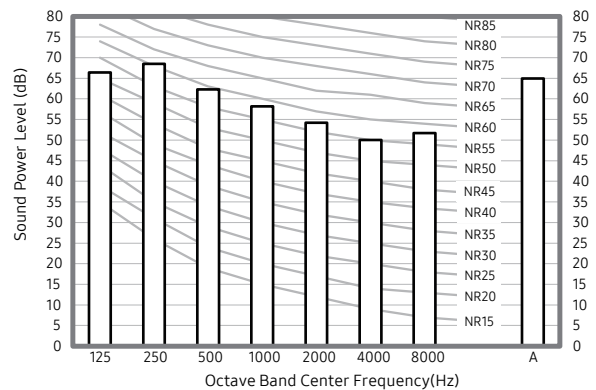

2. Outdoor Units

2-6. Sound data

Sound Power level

Unit: dB(A)

NOTE

- Specifications may be subject to change without prior notice
 - Sound power level is an absolute value that a sound source generates.
 - dBA = A-weighted sound power level.
 - Reference power : 1pW.
 - Measured according to ISO 3741.

Model	Heating	Cooling
AE080CXDYGK/EU	59	59
AE120CXDYGK/EU	60	60
AE160CXDYGK/EU	65	65

- NR Curve

5) AE080CXDYGK/EU

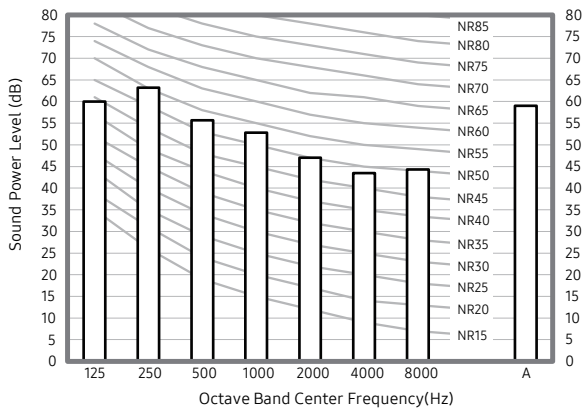

6) AE120CXDYGK/EU

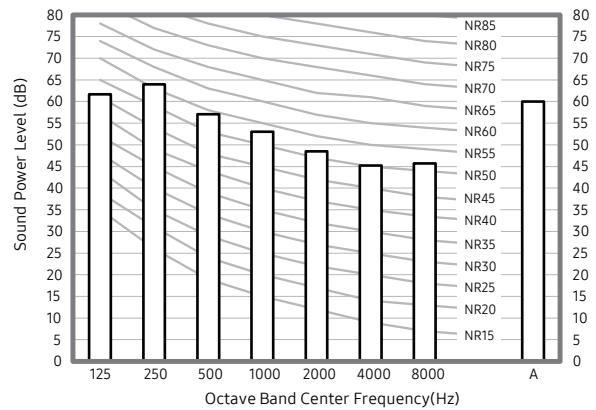

7) AE160CXDYGK/EU

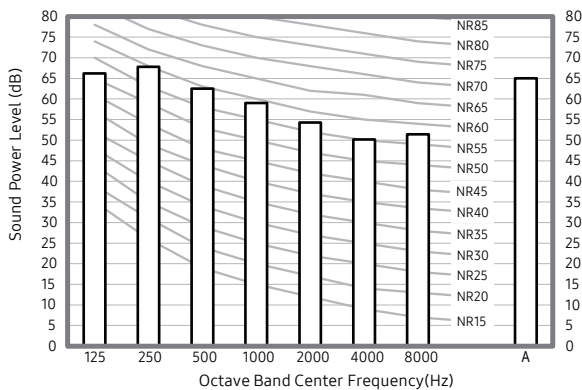

2. Outdoor Units

2-7. Operation range

1) Cooling

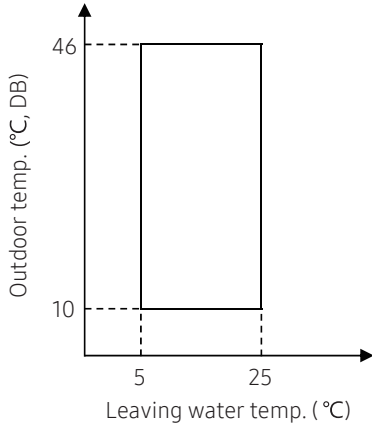

2) Heating

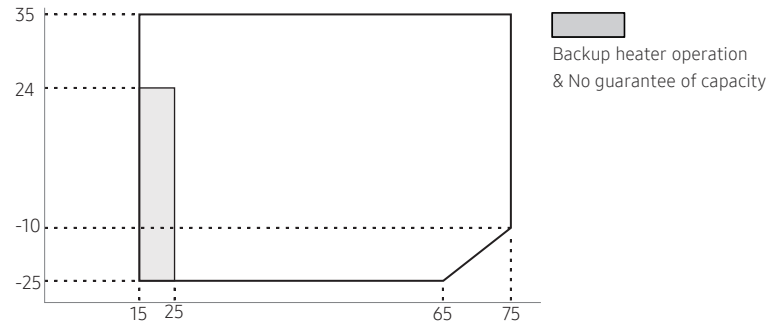

MONO Outdoor Unit		Water Temp. (°C)			Water Flow Rates (LPM)			Air Temp. (°C, DB/WB)		
		Min	Std	Max	Min	Std	Max	Min	Std	Max
Controller	Cooling	5	-	25						
	Heating	15	-	75						
Cooling	Inlet	-	23 (12 ^{*2})	30	7	Δ 5°C	58 (48 ^{*1})	10/-	35/24	46/28
	Outlet	5	18 (7 ^{*2})	25						
Heating	Inlet	5	30 (40 ^{*2})	-				-25/-	7/6	35/24
	Outlet	25 (15 ^{*3})	35 (45 ^{*2})	75						

*1) Model : AE050CXYDEK/EU
AE080CXYD*K/EU

*2) Eurovent Test Condition #2

*3) Back up heater operation.

3) DHW (Domestic Hot Water Tank)

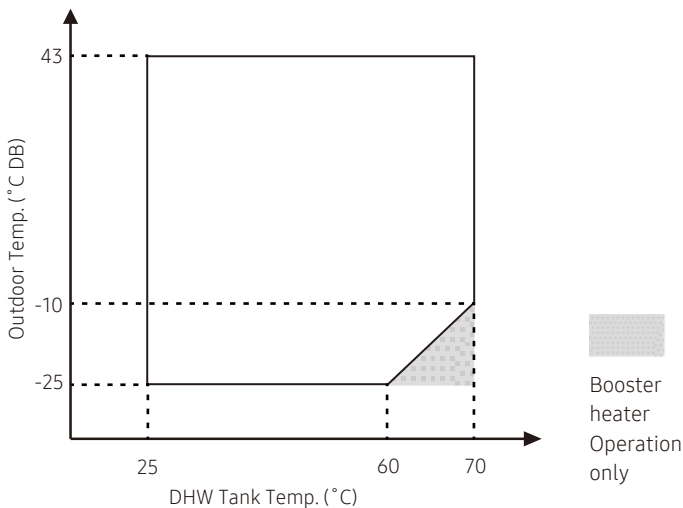

2. Outdoor Units

2-8 Piping diagram

AE050CXYDEK/EU, 080CXYD*K/EU

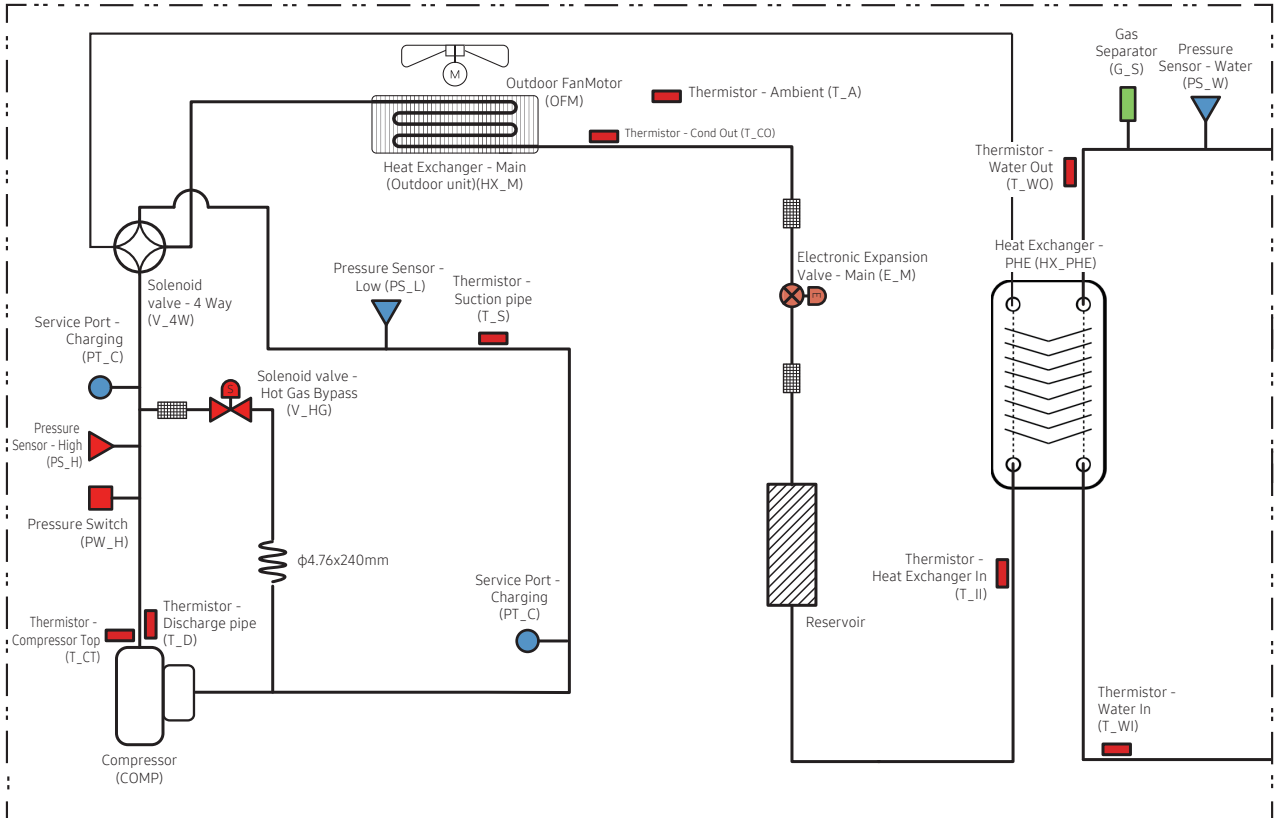

2. Outdoor Units

2-8 Piping diagram

AE120/160CXVD*K/EU

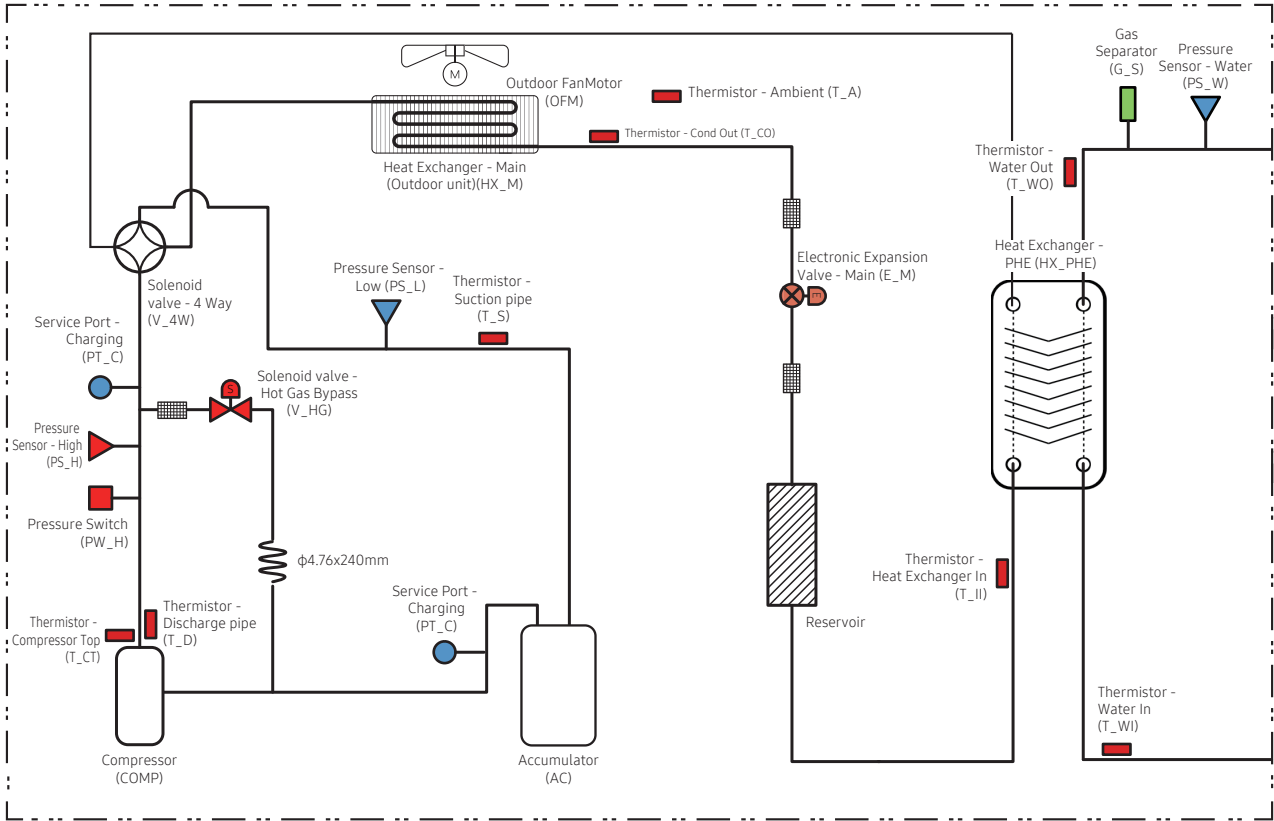

2. Outdoor Units

2-9. Capacity table

3) Cooling Capacity

LWT (Leaving Water Temp.), Tamb (Ambient Temp.), CC (Cooling Capacity), PI (Power input), WF (Water Flow)

Model	LWT(°C)	7			10			13			15			18			25		
	Tamb(°C)	CC (W)	PI (W)	WF(LPM)	CC (W)	PI (W)	WF(LPM)	CC (W)	PI (W)	WF(LPM)	CC (W)	PI (W)	WF(LPM)	CC (W)	PI (W)	WF(LPM)	CC (W)	PI (W)	WF(LPM)
AE050CXYDEK/EU	10	4,485	670	12.9	4,577	670	13.2	4,959	720	14.3	5,244	730	15.1	5,750	730	16.5	6,327	690	18.2
	20	4,290	790	12.3	4,415	800	12.7	4,785	750	13.8	5,060	780	14.6	5,550	830	16.0	6,105	860	17.6
	30	4,095	1,040	11.8	4,253	1,030	12.2	4,611	1,090	13.3	4,876	1,100	14.0	5,350	1,020	15.4	5,883	1,020	17.0
	35	3,900	1,280	11.2	4,050	1,300	11.6	4,350	1,200	12.5	4,600	1,220	13.2	5,000	1,280	14.4	5,550	1,080	16.0
	46	3,650	1,870	10.5	3,850	1,860	11.1	4,120	1,830	11.8	4,420	1,870	12.7	4,800	1,930	13.8	5,246	1,900	15.1
AE080CXYDEK/EU	10	6,560	990	18.8	7,010	1,030	20.1	7,870	1,140	22.6	8,440	1,170	24.3	9,200	1,160	26.5	10,260	1,120	29.6
	20	6,270	1,150	18.0	6,760	1,220	19.4	7,590	1,220	21.8	8,140	1,250	23.4	8,880	1,320	25.6	9,900	1,390	28.5
	30	5,990	1,520	17.2	6,510	1,580	18.7	7,310	1,730	21.0	7,840	1,780	22.5	8,560	1,640	24.6	9,540	1,650	27.5
	35	5,700	1,900	16.4	6,200	1,990	17.8	6,900	1,900	19.8	7,400	1,970	21.3	8,000	2,050	23.1	9,000	1,750	26.0
	46	5,250	2,690	15.1	5,820	2,810	16.7	6,390	2,840	18.4	6,900	2,920	19.8	7,750	3,110	22.3	8,320	3,020	24.0
AE080CXYDGK/EU	10	6,560	990	18.8	7,010	1,030	20.1	7,870	1,140	22.6	8,440	1,170	24.3	9,200	1,160	26.5	10,260	1,120	29.6
	20	6,270	1,150	18.0	6,760	1,220	19.4	7,590	1,220	21.8	8,140	1,250	23.4	8,880	1,320	25.6	9,900	1,390	28.5
	30	5,990	1,520	17.2	6,510	1,580	18.7	7,310	1,730	21.0	7,840	1,780	22.5	8,560	1,640	24.6	9,540	1,650	27.5
	35	5,700	1,900	16.4	6,200	1,990	17.8	6,900	1,900	19.8	7,400	1,970	21.3	8,000	2,050	23.1	9,000	1,750	26.0
	46	5,250	2,690	15.1	5,820	2,810	16.7	6,390	2,840	18.4	6,900	2,920	19.8	7,750	3,110	22.3	8,320	3,020	24.0
AE120CXYDEK/EU	10	10,350	1,590	29.7	10,740	1,600	30.9	11,630	1,650	33.4	12,430	1,690	35.7	13,800	1,700	39.7	15,050	1,470	43.4
	20	9,900	1,850	28.4	10,360	1,890	29.8	11,220	1,780	32.3	11,990	1,800	34.5	13,320	1,930	38.3	14,520	1,770	41.9
	30	9,450	2,440	27.1	9,980	2,450	28.7	10,810	2,490	31.1	11,550	2,550	33.2	12,840	2,400	37.0	13,990	2,030	40.3
	35	9,000	3,100	25.9	9,500	3,070	27.3	10,200	2,700	29.3	10,900	2,830	31.3	12,000	3,000	34.6	13,200	2,230	38.1
	46	7,500	3,920	21.5	8,150	3,970	23.4	9,050	3,920	26.0	9,650	3,970	27.8	10,050	3,940	28.9	12,200	3,970	35.2
AE120CXYDGK/EU	10	10,350	1,590	29.7	10,740	1,600	30.9	11,630	1,650	33.4	12,430	1,690	35.7	13,800	1,700	39.7	15,050	1,470	43.4
	20	9,900	1,850	28.4	10,360	1,890	29.8	11,220	1,780	32.3	11,990	1,800	34.5	13,320	1,930	38.3	14,520	1,770	41.9
	30	9,450	2,440	27.1	9,980	2,450	28.7	10,810	2,490	31.1	11,550	2,550	33.2	12,840	2,400	37.0	13,990	2,030	40.3
	35	9,000	3,100	25.9	9,500	3,070	27.3	10,200	2,700	29.3	10,900	2,830	31.3	12,000	3,000	34.6	13,200	2,230	38.1
	46	8,550	4,620	24.6	9,030	4,400	25.9	9,690	4,200	27.9	10,360	4,260	29.8	11,400	4,470	32.8	12,540	4,080	36.2
AE160CXYDEK/EU	10	11,960	1,910	34.4	12,430	1,930	35.7	13,510	2,060	38.8	14,480	1,990	41.6	16,100	2,090	46.3	17,670	1,820	50.9
	20	11,440	2,190	32.9	11,990	2,220	34.5	13,040	2,210	37.5	13,970	2,200	40.2	15,540	2,370	44.7	17,050	2,190	49.2
	30	10,920	2,880	31.4	11,550	3,000	33.2	12,560	3,110	36.1	13,460	2,960	38.7	14,980	2,940	43.1	16,430	2,510	47.4
	35	10,400	3,590	29.9	11,000	3,590	31.6	11,850	3,350	34.1	12,700	3,480	36.5	14,000	3,680	40.4	15,500	2,750	44.7
	46	7,520	3,940	21.6	8,170	3,990	23.5	9,080	3,940	26.1	9,680	3,970	27.8	10,100	3,960	29.1	12,270	3,980	35.4
AE160CXYDGK/EU	10	11,960	1,910	34.4	12,430	1,930	35.7	13,510	2,060	38.8	14,480	1,990	41.6	16,100	2,090	46.3	17,670	1,820	50.9
	20	11,440	2,190	32.9	11,990	2,220	34.5	13,040	2,210	37.5	13,970	2,200	40.2	15,540	2,370	44.7	17,050	2,190	49.2
	30	10,920	2,880	31.4	11,550	3,000	33.2	12,560	3,110	36.1	13,460	2,960	38.7	14,980	2,940	43.1	16,430	2,510	47.4
	35	10,400	3,590	29.9	11,000	3,590	31.6	11,850	3,350	34.1	12,700	3,480	36.5	14,000	3,680	40.4	15,500	2,750	44.7
	46	9,880	5,340	28.4	10,450	5,150	30.0	11,260	5,000	32.4	12,070	5,070	34.7	13,300	5,340	38.3	14,730	4,990	42.5

1. Heating capacity

- Capacity is according to EN14511.
- Valid for heated water range (ΔT = Leaving water temperature - Entering water temperature)
: If $LWT \leq 50^\circ C$, $\Delta T = 5^\circ C$ or $50^\circ C < LWT \leq 60^\circ C$, $\Delta T = 8^\circ C$ or $LWT > 60^\circ C$, $\Delta T = 10^\circ C$, within the minimum ~ maximum water flow rate.

2. Cooling capacity

- Capacity is according to EN14511.
- Valid for Cooling water range (ΔT = Entering water temperature - Leaving water temperature)
: $\Delta T = 5^\circ C$, within the minimum ~ maximum water flow rate.

3. Power input : Power input is according to EN14511.

4. Peak value : Tested without defrost operation in accordance with EN14511.

※ The real capacity would be changed according to the install environment.

2. Outdoor Units

2-10. Silent mode corrections

Heating

Silent Function	Outdoor Air Temperature(°C DB)			
	-15	2	7	15
Level 1	0.92	0.90	0.95	0.95
Level 2	0.82	0.80	0.86	0.86
Level 3	0.68	0.67	0.72	0.72
Low-noise	0.54	0.60	0.65	0.65

Cooling

Silent Function	Outdoor Air Temperature(°C DB)			
	10	20	35	45
Level 1	1.00	1.00	0.95	0.95
Level 2	0.98	0.98	0.86	0.86
Level 3	0.78	0.78	0.65	0.65
Low-noise	0.70	0.70	0.65	0.65

Correction factor by % glycol

Anti-freeze	Propylene glycol	
	Correction factor	
	Capacity	Power Input
0%	1.000	1.000
10%	0.988	0.994
20%	0.973	0.988
30%	0.955	0.982
40%	0.933	0.976
50%	0.910	0.970

3. Tank integrated hydro unit

3-1. Specifications

Model Name		Indoor Unit		AE200CNWMEG/EU	AE200CNWMEG/EU	AE200CNWMEG/EU	AE200CNWMEG/EU	
		Outdoor Unit		AE050CXYDEK/EU	AE080CXYDEK/EU	AE120CXYDEK/EU	AE160CXYDEK/EU	
Mode		-		Heat Pump (A2W)	Heat Pump (A2W)	Heat Pump (A2W)	Heat Pump (A2W)	
Power Supply		Φ, #, V, Hz		1,2,220-240,50	1,2,220-240,50	1,2,220-240,50	1,2,220-240,50	
Power input	Cooling (Nominal)	kW		0.2	0.2	0.2	0.2	
	Heating (Nominal)	kW		0.2	0.2	0.2	0.2	
	Cooling (Max)	kW		0.2	0.2	0.2	0.2	
	Heating (Max)	kW		5.2	5.2	5.2	5.2	
Current Input	Cooling (Nominal)	A		0.9	0.9	0.9	0.9	
	Heating (Nominal)	A		0.9	0.9	0.9	0.9	
	Cooling (Max)	A		0.9	0.9	0.9	0.9	
	Heating (Max)	A		22.7	22.7	22.7	22.7	
Field Wiring	MCA	A		22.7	22.7	22.7	22.7	
	MFA			28.4	28.4	28.4	28.4	
Heating up time		h / min		2 / 20	1 / 25	1 / 0	1 / 0	
Water Heating	Declared load profile		-		L	L	L	L
	Energy efficiency Class		-		A+	A+	A+	A+
Water Connections	Water Flow Rate (Std)[H/C]		LPM		14.4	23.1	34.6	46.2 / 40.4
	Water Pressure (Max)		bar		3	3	3	3
	Water pipe (To outdoor unit)	Type	-		Straight pipe	Straight pipe	Straight pipe	Straight pipe
		Inlet	Φ, mm		28	28	28	28
		Outlet	Φ, mm		28	28	28	28
	Water pipe (Space heating)	Type	-		Straight pipe	Straight pipe	Straight pipe	Straight pipe
		Inlet	Φ, mm		28	28	28	28
		Outlet	Φ, mm		28	28	28	28
	Water pipe (DHW)	Type	-		Straight pipe	Straight pipe	Straight pipe	Straight pipe
		Inlet	Φ, mm		22	22	22	22
		Outlet	Φ, mm		22	22	22	22
	Water pipe (Secondary water return, Only 260L)	Type	-		-	-	-	-
		Inlet	Φ, mm		-	-	-	-
	Leaving Water Temperature	Heating	°C		15~75	15~75	15~75	15~75
Cooling		°C		5~25	5~25	5~25	5~25	
DHW Tank	Nominal Water Volume		liter		200	200	200	200
	Net Water Volume		liter		194	194	194	194
	Material		-		SUS 316L	SUS 316L	SUS 316L	SUS 316L
	Max. water pressure		bar		10	10	10	10
	Max. water temperature		°C		70	70	70	70
	Immersion heater (= booster heater)		kW		3 (230V)	3 (230V)	3 (230V)	3 (230V)
	Insulation		-		PU Foam	PU Foam	PU Foam	PU Foam
Water Pump	Type		-		Centrifurugal (GPA 25-9H)	Centrifurugal (GPA 25-9H)	Centrifurugal (GPA 25-9H)	Centrifurugal (GPA 25-9H)
	Motor Input		W		100	100	100	100
	Number of Unit		EA		1	1	1	1
Backup Heater	Power		kW		2 (230V)	2 (230V)	2 (230V)	2 (230V)
	Thermostat		°C		85±4	85±4	85±4	85±4
	Thermostat (Thermal Fuse)		°C		98 +0 -5	98 +0 -5	98 +0 -5	98 +0 -5
Safety device	Pressure relief valve		bar		2.9	2.9	2.9	2.9
	Flow Sensor		LPM		5~60	5~60	5~60	5~60
	Temperature & Pressure relief valve(Tank)		bar, °C		7, 90	7, 90	7, 90	7, 90
	Thermostat (for immersion heater)		°C		80 ±5 (Auto) 90 ±5 (Manual)	80 ±5 (Auto) 90 ±5 (Manual)	80 ±5 (Auto) 90 ±5 (Manual)	80 ±5 (Auto) 90 ±5 (Manual)

3. Tank integrated hydro unit

3-1. Specifications

Model Name		Indoor Unit		AE200CNWMEG/EU	AE200CNWMEG/EU	AE200CNWMEG/EU	AE200CNWMEG/EU
		Outdoor Unit		AE050CXYDEK/EU	AE080CXYDEK/EU	AE120CXYDEK/EU	AE160CXYDEK/EU
Expansion vessel	Internal water volume		liter	8	8	8	8
	Working pressure		MPa	0.3	0.3	0.3	0.3
Water Pump (Primary)	Type		-	BLDC Inv	BLDC Inv	BLDC Inv	BLDC Inv
	Max static pressure		mAq	9.0	9.0	9.0	9.0
Water Heat Exchanger	Type		-	Braszed Plate Exchanger	Braszed Plate Exchanger	Braszed Plate Exchanger	Braszed Plate Exchanger
	Quantity		EA	1	1	1	1
	Internal water volume		L	1.01(Water Side) 0.98(Refrigerant Side)	1.01(Water Side) 0.98(Refrigerant Side)	1.01(Water Side) 0.98(Refrigerant Side)	1.01(Water Side) 0.98(Refrigerant Side)
	Water flow rate	Min.	l/min	7	7	7	7
		Max.	l/min	48	48	58	58
Insulation material		-	PE-FOAM	PE-FOAM	PE-FOAM	PE-FOAM	
IP Class		-	IPX1	IPX1	IPX1	IPX1	
Air Purge Valve		Φ, inch	BSPP male 3/8	BSPP male 3/8	BSPP male 3/8	BSPP male 3/8	
Sound Level	Sound Pressure Level	Heating	dB(A)	26	26	30	30
		Cooling	dB(A)	26	26	30	30
	Sound Power Level	Heating	dB(A)	40	40	44	44
Casing	Color		-	Earth brown	Earth brown	Earth brown	Earth brown
	Material		-	Poweder coated Galvanised steel	Poweder coated Electro galvanized steel	Poweder coated Electro galvanized steel	Poweder coated Electro galvanized steel
Packing	Material		-	EPS/BOX	EPS/BOX	EPS/BOX	EPS/BOX
	Packing Weight		kg	12.0	12.0	12.0	12.0
External Dimension	Net Weight		kg	128.0	128.0	128.0	128.0
	Shipping Weight		kg	140.0	140.0	140.0	140.0
	Net Dimensions (WxHxD)		mm	595 x 1,800 x 700	595 x 1,800 x 700	595 x 1,800 x 700	595 x 1,800 x 700
	Shipping Dimensions (WxHxD)		mm	700 x 2,000 x 780	700 x 2,000 x 780	700 x 2,000 x 780	700 x 2,000 x 780

NOTE

- Specifications may be subject to change without prior notice.

3. Tank integrated hydro unit

3-1. Specifications

Model Name		Indoor Unit		AE260CNWMEG/EU	AE260CNWMEG/EU	AE260CNWMEG/EU	
		Outdoor Unit		AE080CXYDEK/EU	AE120CXYDEK/EU	AE160CXYDEK/EU	
Mode		-		Heat Pump (A2W)	Heat Pump (A2W)	Heat Pump (A2W)	
Power Supply		Φ, #, V, Hz		1,2,220-240,50	1,2,220-240,50	1,2,220-240,50	
Power input	Cooling (Nominal)	kW		0.2	0.2	0.2	
	Heating (Nominal)	kW		0.2	0.2	0.2	
	Cooling (Max)	kW		0.2	0.2	0.2	
	Heating (Max)	kW		5.2	5.2	5.2	
Current Input	Cooling (Nominal)	A		0.9	0.9	0.9	
	Heating (Nominal)	A		0.9	0.9	0.9	
	Cooling (Max)	A		0.9	0.9	0.9	
	Heating (Max)	A		22.7	22.7	22.7	
Field Wiring	MCA	A		22.7	22.7	22.7	
	MFA			28.4	28.4	28.4	
Heating up time		h /min		1 / 50	1 / 20	1 / 20	
Water Heating	Declared load profile	-		XL	XL	XL	
	Energy efficiency Class	-		A	A	A	
Water Connections	Water Flow Rate (Std)[H/C]		LPM	23.1	34.6	46.2 / 40.4	
	Water Pressure (Max)		bar	3	3	3	
	Water pipe (To outdoor unit)	Type	-		Straight pipe	Straight pipe	Straight pipe
		Inlet	Φ, mm	28	28	28	
		Outlet	Φ, mm	28	28	28	
	Water pipe (Space heating)	Type	-		Straight pipe	Straight pipe	Straight pipe
		Inlet	Φ, mm	28	28	28	
		Outlet	Φ, mm	28	28	28	
	Water pipe (DHW)	Type	-		Straight pipe	Straight pipe	Straight pipe
		Inlet	Φ, mm	22	22	22	
		Outlet	Φ, mm	22	22	22	
	Water pipe (Secondary water return, Only 260L)	Type	-		-	Straight pipe	Straight pipe
		Inlet	Φ, mm	-	-	22	22
	Leaving Water Temperature	Heating	°C		15~75	15~75	15~75
Cooling		°C		5~25	5~25	5~25	
DHW Tank	Nominal Water Volume		liter	200	260	260	
	Net Water Volume		liter	194	254	254	
	Material		-	SUS 316L	SUS 316L	SUS 316L	
	Max. water pressure		bar	10	10	10	
	Max. water temperature		°C	70	70	70	
	Immersion heater (= booster heater)		kW	3 (230V)	3 (230V)	3 (230V)	
	Insulation		-	PU Foam	PU Foam	PU Foam	
Water Pump	Type		-	Centrifurugal (GPA 25-9H)	Centrifurugal (GPA 25-9H)	Centrifurugal (GPA 25-9H)	
	Motor Input		W	100	100	100	
	Number of Unit		EA	1	1	1	
Backup Heater	Power		kW	2 (230V)	2 (230V)	2 (230V)	
	Thermostat		°C	85±4	85±4	85±4	
	Thermostat (Thermal Fuse)		°C	98 +0 -5	98 +0 -5	98 +0 -5	
Safety device	Pressure relief valve		bar	2.9	2.9	2.9	
	Flow Sensor		LPM	5~60	5~60	5~60	
	Temperature & Pressure relief valve(Tank)		bar, °C	7, 90	7, 90	7, 90	
	Thermostat (for immersion heater)		°C	80 ±5 (Auto) 90 ±5 (Manual)	80 ±5 (Auto) 90 ±5 (Manual)	80 ±5 (Auto) 90 ±5 (Manual)	

3. Tank integrated hydro unit

3-1. Specifications

Model Name		Indoor Unit		AE260CNWMEG/EU	AE260CNWMEG/EU	AE260CNWMEG/EU
		Outdoor Unit		AE080CXYDEK/EU	AE120CXYDEK/EU	AE160CXYDEK/EU
Expansion vessel	Internal water volume		liter	8	8	8
	Working pressure		MPa	0.3	0.3	0.3
Water Pump (Primary)	Type		-	BLDC Inv	BLDC Inv	BLDC Inv
	Max static pressure		mAq	9.0	9.0	9.0
Water Heat Exchanger	Type		-	Braszed Plate Exchager	Braszed Plate Exchager	Braszed Plate Exchager
	Quantity		EA	1	1	1
	Internal water volume		L	1.01(Water Side) 0.98(Refrigerant Side)	1.01(Water Side) 0.98(Refrigerant Side)	1.01(Water Side) 0.98(Refrigerant Side)
	Water flow rate	Min.	l/min	7	7	7
		Max.	l/min	58	48	58
Insulation material		-	PE-FOAM	PE-FOAM	PE-FOAM	
IP Class		-	IPX1	IPX1	IPX1	
Air Purge Valve		Φ, inch	BSPP male 3/8	BSPP male 3/8	BSPP male 3/8	
Sound Level	Sound Pressure Level	Heating	dB(A)	26	30	30
		Cooling	dB(A)	26	30	30
	Sound Power Level	Heating	dB(A)	40	44	44
Casing	Color		-	Earth brown	Earth brown	Earth brown
	Material		-	Poweder coated Electro galvanized steel	Poweder coated Electro galvanized steel	Poweder coated Electro galvanized steel
Packing	Material		-	EPS/BOX	EPS/BOX	EPS/BOX
	Packing Weight		kg	12.0	12.0	12.0
External Dimension	Net Weight		kg	128.0	136.0	136.0
	Shipping Weight		kg	140.0	148.0	148.0
	Net Dimensions (WxHxD)		mm	595 x 1,800 x 700	595 x 1,800 x 700	595 x 1,800 x 700
	Shipping Dimensions (WxHxD)		mm	700 x 2,000 x 780	700 x 2,000 x 780	700 x 2,000 x 780

NOTE

- Specifications may be subject to change without prior notice.

3. Tank integrated hydro unit

3-1. Specifications

Model Name		Indoor Unit		AE260CNWMGG/EU	AE260CNWMGG/EU	AE260CNWMGG/EU	
		Outdoor Unit		AE080CXVDGK/EU	AE120CXVDGK/EU	AE160CXVDGK/EU	
Mode		-		Heat Pump (A2W)	Heat Pump (A2W)	Heat Pump (A2W)	
Power Supply		Φ, #, V, Hz		1,2,220-240,50 3,4,380-415,50	1,2,220-240,50 3,4,380-415,50	1,2,220-240,50 3,4,380-415,50	
Power input	Cooling (Nominal)	kW		3Φ - / 1Φ 0.20	3Φ - / 1Φ 0.20	3Φ - / 1Φ 0.20	
	Heating (Nominal)	kW		3Φ - / 1Φ 0.20	3Φ - / 1Φ 0.20	3Φ - / 1Φ 0.20	
	Cooling (Max)	kW		3Φ - / 1Φ 0.20	3Φ - / 1Φ 0.20	3Φ - / 1Φ 0.20	
	Heating (Max)	kW		3Φ 6.00 / 1Φ 3.20	3Φ 6.00 / 1Φ 3.20	3Φ 6.00 / 1Φ 3.20	
Current Input	Cooling (Nominal)	A		3Φ - / 1Φ 0.9	3Φ - / 1Φ 0.9	3Φ - / 1Φ 0.9	
	Heating (Nominal)	A		3Φ - / 1Φ 0.9	3Φ - / 1Φ 0.9	3Φ - / 1Φ 0.9	
	Cooling (Max)	A		3Φ - / 1Φ 0.9	3Φ - / 1Φ 0.9	3Φ - / 1Φ 0.9	
	Heating (Max)	A		3Φ 8.7 / 1Φ 14.0	3Φ 8.7 / 1Φ 14.0	3Φ 8.7 / 1Φ 14.0	
Field Wiring	MCA	A		3Φ 8.7 / 1Φ 14.0	3Φ 8.7 / 1Φ 14.0	3Φ 8.7 / 1Φ 14.0	
	MFA			3Φ 10.9 / 1Φ 17.5	3Φ 10.9 / 1Φ 17.5	3Φ 10.9 / 1Φ 17.5	
Heating up time		h / min		1 / 50	1 / 20	1 / 20	
Water Heating	Declared load profile	-		XL	XL	XL	
	Energy efficiency Class	-		A	A	A	
Water Connections	Water Flow Rate (Std)[H/C]		LPM	23.1	34.6	46.2 / 40.4	
	Water Pressure (Max)		bar	3	3	3	
	Water pipe (To outdoor unit)	Type	-		Straight pipe	Straight pipe	Straight pipe
		Inlet	Φ, mm	28	28	28	
		Outlet	Φ, mm	28	28	28	
	Water pipe (Space heating)	Type	-		Straight pipe	Straight pipe	Straight pipe
		Inlet	Φ, mm	28	28	28	
		Outlet	Φ, mm	28	28	28	
	Water pipe (DHW)	Type	-		Straight pipe	Straight pipe	Straight pipe
		Inlet	Φ, mm	22	22	22	
		Outlet	Φ, mm	22	22	22	
	Water pipe (Secondary water return, Only 260L)	Type	-		Straight pipe	Straight pipe	Straight pipe
		Inlet	Φ, mm	22	22	22	
	Leaving Water Temperature	Heating	°C	15~75	15~75	15~75	
Cooling		°C	5~25	5~25	5~25		
DHW Tank	Nominal Water Volume		liter	260	260	260	
	Net Water Volume		liter	254	254	254	
	Material		-	SUS 316L	SUS 316L	SUS 316L	
	Max. water pressure		bar	10	10	10	
	Max. water temperature		°C	70	70	70	
	Immersion heater (= booster heater)		kW	3 (230V)	3 (230V)	3 (230V)	
	Insulation		-	PU Foam	PU Foam	PU Foam	
Water Pump	Type		-	Centrifurugal (GPA 25-9H)	Centrifurugal (GPA 25-9H)	Centrifurugal (GPA 25-9H)	
	Motor Input		W	100	100	100	
	Number of Unit		EA	1	1	1	
Backup Heater	Power		kW	6 (3Φ 400V)	6 (3Φ 400V)	6 (3Φ 400V)	
	Thermostat		°C	85±4	85±4	85±4	
	Thermostat (Thermal Fuse)		°C	98 +0 -5	98 +0 -5	98 +0 -5	
Safety device	Pressure relief valve		bar	2.9	2.9	2.9	
	Flow Sensor		LPM	5~60	5~60	5~60	
	Temperature & Pressure relief valve(Tank)		bar, °C	7, 90	7, 90	7, 90	
	Thermostat (for immersion heater)		°C	80 ±5 (Auto) 90 ±5 (Manual)	80 ±5 (Auto) 90 ±5 (Manual)	80 ±5 (Auto) 90 ±5 (Manual)	

3. Tank integrated hydro unit

3-1. Specifications

Model Name		Indoor Unit		AE260CNWMGG/EU	AE260CNWMGG/EU	AE260CNWMGG/EU
		Outdoor Unit		AE080CXYDGK/EU	AE120CXYDGK/EU	AE160CXYDGK/EU
Expansion vessel	Internal water volume		liter	8	8	8
	Working pressure		MPa	0.3	0.3	0.3
Water Pump (Primary)	Type		-	BLDC Inv	BLDC Inv	BLDC Inv
	Max static pressure		mAq	9.0	9.0	9.0
Water Heat Exchanger	Type		-	Braszed Plate Exchager	Braszed Plate Exchager	Braszed Plate Exchager
	Quantity		EA	1	1	1
	Internal water volume		L	1.01(Water Side) 0.98(Refrigerant Side)	1.01(Water Side) 0.98(Refrigerant Side)	1.01(Water Side) 0.98(Refrigerant Side)
	Water flow rate	Min.	l/min	7	7	7
		Max.	l/min	48	58	58
Insulation material		-	PE-FOAM	PE-FOAM	PE-FOAM	
IP Class		-	IPX1	IPX1	IPX1	
Air Purge Valve		Φ, inch	BSPP male 3/8	BSPP male 3/8	BSPP male 3/8	
Sound Level	Sound Pressure Level	Heating	dB(A)	26	30	30
		Cooling	dB(A)	26	30	30
	Sound Power Level	Heating	dB(A)	40	44	44
Casing	Color		-	Earth brown	Earth brown	Earth brown
	Material		-	Poweder coated Electro galvanized steel	Poweder coated Electro galvanized steel	Poweder coated Electro galvanized steel
Packing	Material		-	EPS/BOX	EPS/BOX	EPS/BOX
	Packing Weight		kg	12.0	12.0	12.0
External Dimension	Net Weight		kg	138.0	138.0	138.0
	Shipping Weight		kg	150.0	150.0	150.0
	Net Dimensions (WxHxD)		mm	595 x 1,800 x 700	595 x 1,800 x 700	595 x 1,800 x 700
	Shipping Dimensions (WxHxD)		mm	700 x 2,000 x 780	700 x 2,000 x 780	700 x 2,000 x 780

NOTE

- Specifications may be subject to change without prior notice.

3. Tank integrated hydro unit

3-2. Dimensional drawing

AE200/260CNWM*G/EU

Unit : mm

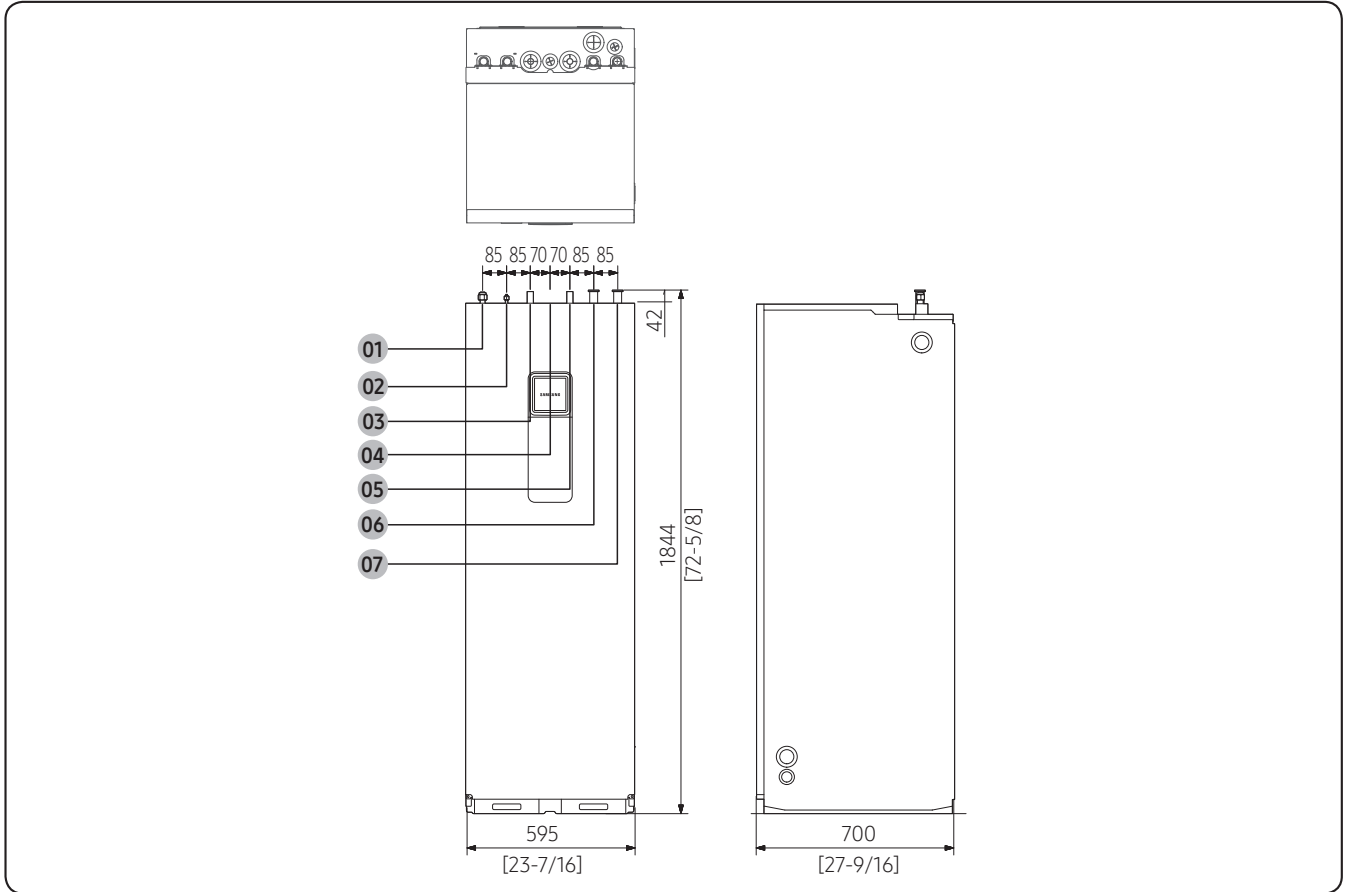

NO	Name	Description
01	Mono outdoor outlet	Ø28, T1.2
02	Mono outdoor inlet	Ø28, T1.2
03	Hot water outlet	Ø22, T1.0
04	Secondary return (260L option)	Ø22, T1.0
05	Cold water inlet	Ø22, T1.0
06	Space heating outlet	Ø28, T1.2
07	Space heating inlet	Ø28, T1.2

3. Tank integrated hydro unit

3-2. Dimensional drawing

Main components

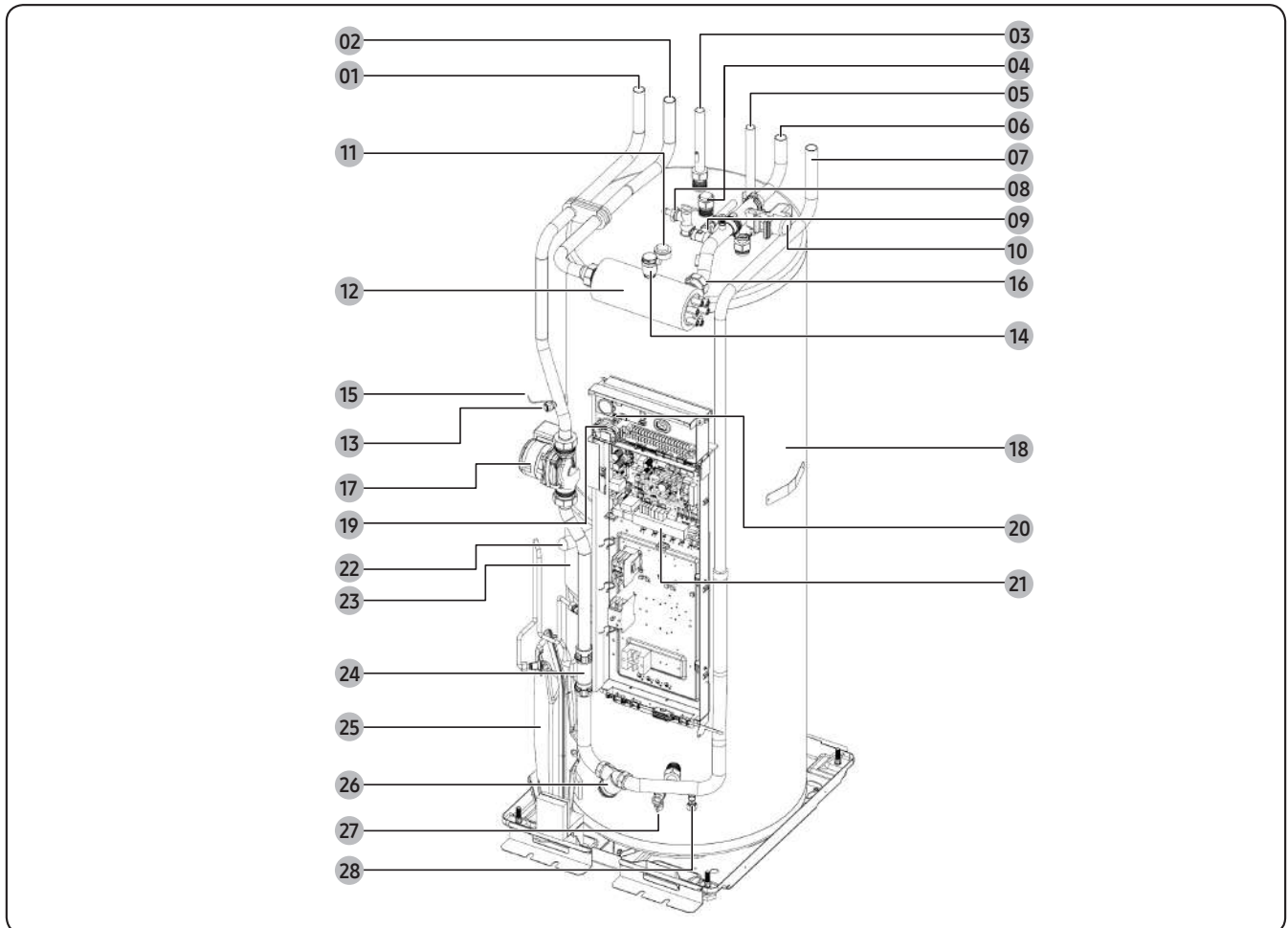

NO	Part name	Note	NO	Part name	Note
01	Water pipe (Return to heat pump)	ø28, Straight pipe	15	Tank thermistor	
02	Water pipe (Flow from heat pump)	ø28, Straight pipe	16	Heater thermistor	
03	Hot water outlet	ø22, Straight pipe	17	Water pump	
04	Secondary return	ø22, Straight pipe (260 L option)	18	Water tank	200 L / 260 L
05	Cold water inlet	ø22, Straight pipe	19	Manometer	0~4 bar
06	Space heating outlet	ø28, Straight pipe	20	S/D converter	
07	Space heating inlet	ø28, Straight pipe	21	Control box	
08	T/P valve	7 bar, 90°C	22	Booster heater	3kW
09	Pressure relief valve	3 bar, BSPP 1/2"	23	Booster heater thermostat	
10	3-way valve		24	Flow sensor	
11	Anode bar	BSPP 1"	25	Expansion vessel	8 L, Pre-charge gas: 0.1 MPa, N2, BSPP 3/8"
12	Back-up heater		26	Strainer	
13	Drain port		27	Tank drain valve	
14	Air vent	BSPP 3/8"	28	Drain port	Primary circuit

3. Tank integrated hydro unit

3-3. Electrical wiring diagram

AE200/260CNWMEG/EU

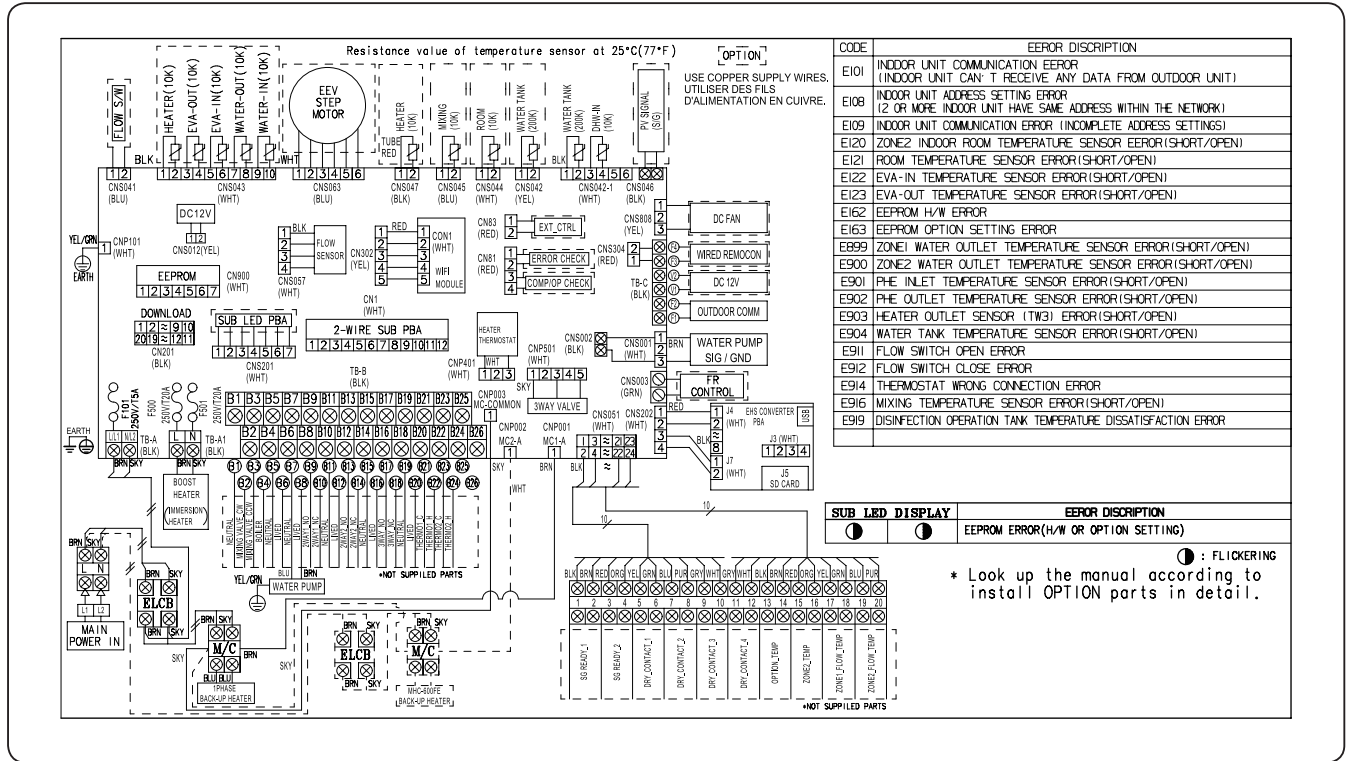

* It does not support external input(CNS083)/output(CNS081) signal function

HEATER	Thermistor HEATER(10K)	EVA-OUT	Thermistor EVA-OUT(10K)
EVA-IN	Thermistor EVA-IN(10K)	WATER-OUT	Thermistor WATER-OUT(10K)
WATER-IN	Thermistor WATER-IN(10K)	WATER TANK	Thermistor WATER TANK(200K)
MIXING	Thermistor MIXING VALVE(10K)	DHW-IN	Thermistor DHW-IN (10K)
OUTDOOR COMM	Outdoor Communication	WIRED REMOCON	Wired Remote Controller
ELCB	Earth Leakage Circuit Breaker	SIG/GND	Signal/Ground
		M/C	Magnetic Contactor

NOTES

1. This wiring diagram applies only to the Indoor unit.
2. Symbols show as follow :
blk: black, red: red, blu: blue, wht: white, yel: yellow, brn: brown, sky: skyblue, grn: green
3. For connection wiring indoor-outdoor transmission F1-F2, indoor-wired remote controller transmission F3-F4.
4. ⚡ Protective earth(SCREW)

3. Tank integrated hydro unit

3-3. Electrical wiring diagram

AE260CNWMGG/EU

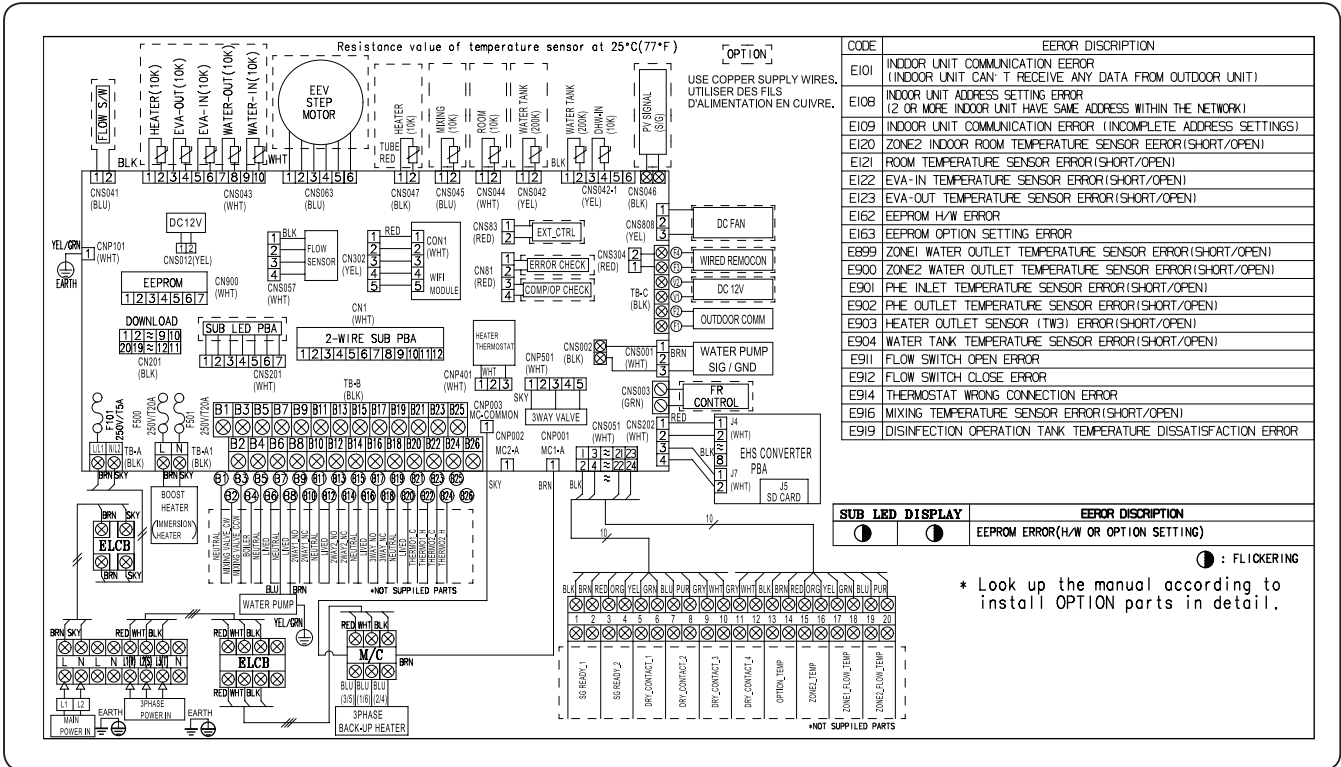

※ It does not support external input(CNS083)/output(CNS081) signal function

HEATER	Thermistor HEATER(10K)	EVA-OUT	Thermistor EVA-OUT(10K)
EVA-IN	Thermistor EVA-IN(10K)	WATER-OUT	Thermistor WATER-OUT(10K)
WATER-IN	Thermistor WATER-IN(10K)	WATER TANK	Thermistor WATER TANK(200K)
MIXING	Thermistor MIXING VALVE(10K)	DHW-IN	Thermistor DHW-IN (10K)
OUTDOOR COMM	Outdoor Communication	WIRED REMOCON	Wired Remote Controller
ELCB	Earth Leakage Circuit Breaker	SIG/GND	Signal/Ground
		M/C	Magnetic Contactor

NOTES

1. This wiring diagram applies only to the Indoor unit.
2. Symbols show as follow :
blk: black, red: red, blu: blue, wht: white, yel: yellow, brn: brown, sky: skyblue, grn: green
3. For connection wiring indoor-outdoor transmission F1-F2, indoor-wired remote controller transmission F3-F4.
4. ⚡ Protective earth(SCREW)

3. Tank integrated hydro unit

3-4. Sound data

Capacity (Liter)	Model	Sound Pressure dB(A) (Heating)	Sound Power dB(A) (Heating)
200	AE200CNWMEG/EU+AE050CXYDEK/EU	26	40
	AE200CNWMEG/EU+AE080CXYDEK/EU	26	40
	AE200CNWMEG/EU+AE120CXYDEK/EU	30	44
	AE200CNWMEG/EU+AE140CXYDEK/EU	30	44
260	AE260CNWM*G/EU+AE080CXYD*K/EU	26	40
	AE260CNWM*G/EU+AE120CXYD*K/EU	30	44
	AE260CNWM*G/EU+AE140CXYD*K/EU	30	44

NOTE

- Specifications may be subject to change without prior notice.
- Sound Pressure Level
 - Sound pressure level is obtained in an anechoic room.
 - Sound pressure level is a relative value, depending on the distance and acoustic environment.
 - Sound pressure level may differ depending on operation condition.
 - dBA = A-weighted sound pressure level
 - Reference acoustic pressure 0 dB = 20μPa
- Sound Power Level
 - Sound power level is an absolute value that a sound source generates.
 - dBA = A-weighted sound power level.
 - Reference power : 1pW.
 - Measured according to ISO 3741.

3. Tank integrated hydro unit

3-4. Sound data

Sound Pressure level

Unit: dB(A)

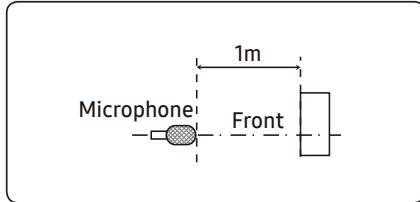

Model	Heating
AE200*NWMEG/EU+AE050CXYDEK/EU	26
AE200*NWMEG/EU+AE080CXYDEK/EU	26
AE200*NWMEG/EU+AE120CXYDEK/EU	30
AE200*NWMEG/EU+AE160CXYDEK/EU	30

- NR Curve

1) AE200*NWMEG/EU+AE050CXYDEK/EU

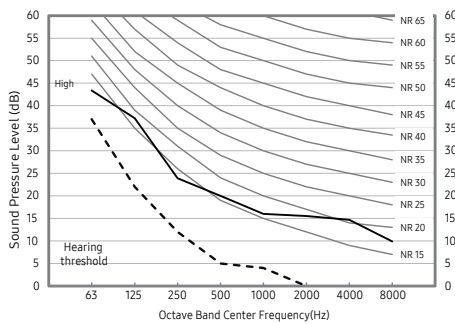

2) AE200*NWMEG/EU+AE080CXYDEK/EU

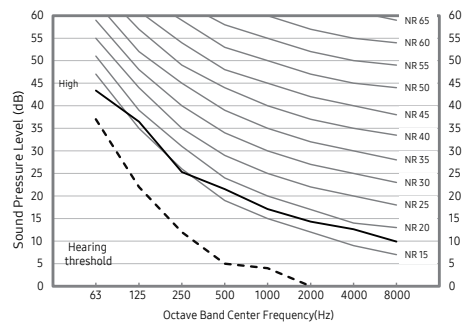

3) AE200*NWMEG/EU+AE120CXYDEK/EU

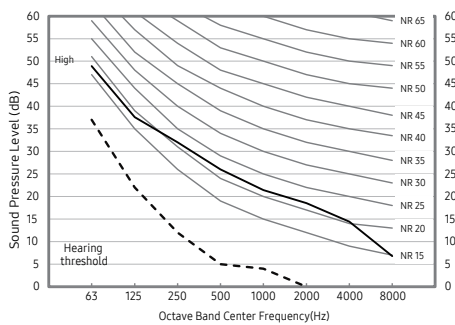

4) AE200*NWMEG/EU+AE160CXYDEK/EU

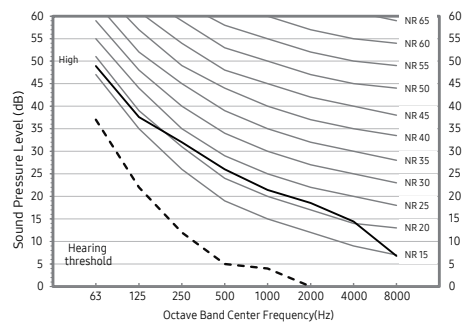

NOTE

- Specifications may be subject to change without prior notice.
- Sound Pressure Level
 - Sound pressure level is obtained in an anechoic room.
 - Sound pressure level is a relative value, depending on the distance and acoustic environment.
 - Sound pressure level may differ depending on operation condition.
 - dBA = A weighted sound pressure level
 - Reference acoustic pressure 0 dB = 20μPa

3. Tank integrated hydro unit

3-4. Sound data

Sound Pressure level

Unit: dB(A)

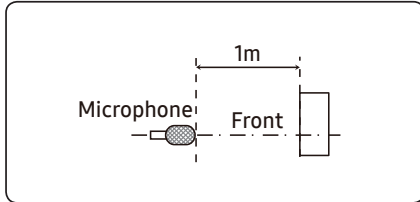

Model	Heating
AE260*NWMEG/EU+AE080CXYDEK/EU	26
AE260*NWMEG/EU+AE120CXYDEK/EU	30
AE260*NWMEG/EU+AE160CXYDEK/EU	30

- NR Curve

1) AE260*NWMEG/EU+AE080CXYDEK/EU

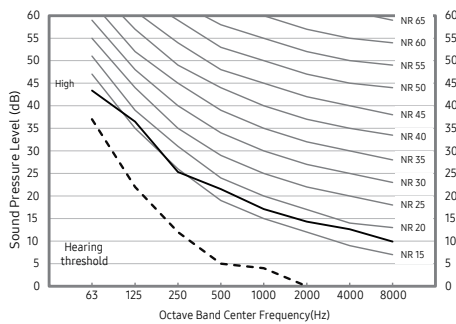

2) AE260*NWMEG/EU+AE120CXYDEK/EU

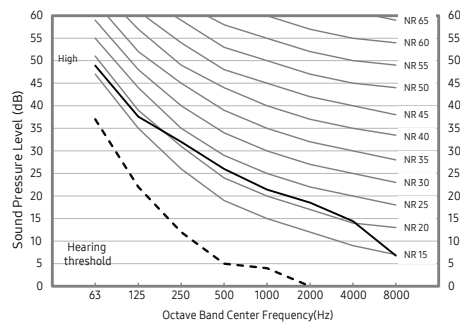

3) AE260*NWMEG/EU+AE160CXYDEK/EU

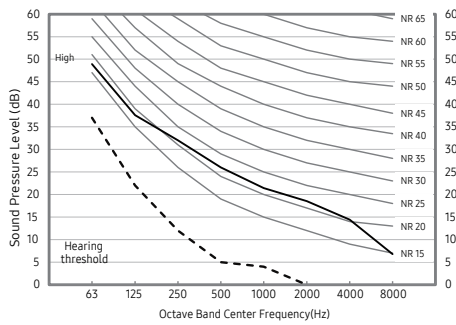

NOTE

- Specifications may be subject to change without prior notice.
- Sound Pressure Level
 - Sound pressure level is obtained in an anechoic room.
 - Sound pressure level is a relative value, depending on the distance and acoustic environment.
 - Sound pressure level may differ depending on operation condition.
 - dBA = A weighted sound pressure level
 - Reference acoustic pressure 0 dB = 20μPa

3. Tank integrated hydro unit

3-4. Sound data

Sound Pressure level

Unit: dB(A)

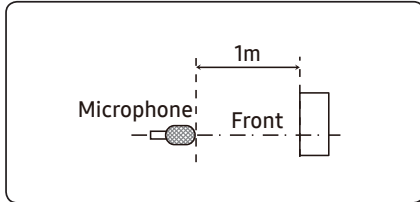

Model	Heating
AE260*NWMGG/EU+AE080CXYDGK/EU	26
AE260*NWMGG/EU+AE120CXYDGK/EU	30
AE260*NWMGG/EU+AE160CXYDGK/EU	30

- NR Curve

1) AE260*NWMGG/EU+AE080CXYDGK/EU

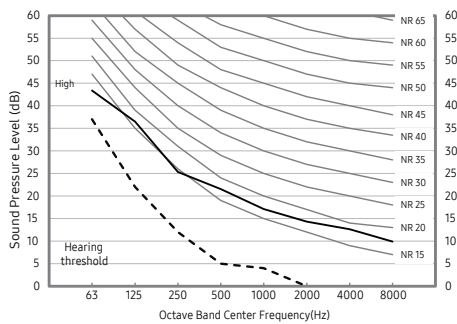

2) AE260*NWMGG/EU+AE120CXYDGK/EU

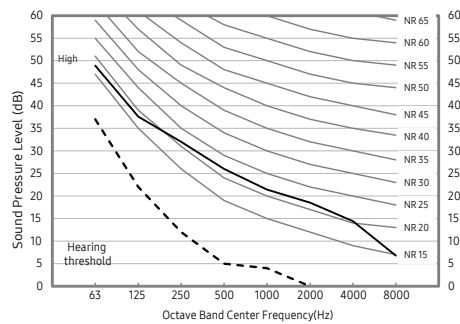

3) AE260*NWMGG/EU+AE160CXYDGK/EU

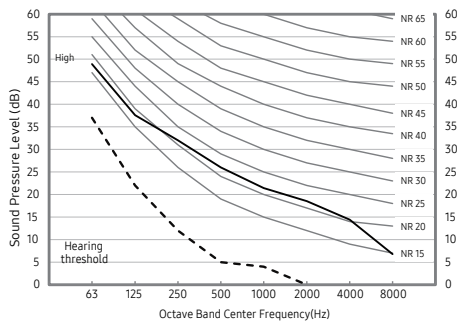

NOTE

- Specifications may be subject to change without prior notice.
- Sound Pressure Level
 - Sound pressure level is obtained in an anechoic room.
 - Sound pressure level is a relative value, depending on the distance and acoustic environment.
 - Sound pressure level may differ depending on operation condition.
 - dBA = A weighted sound pressure level
 - Reference acoustic pressure 0 dB = 20μPa

3. Tank integrated hydro unit

3-4. Sound data

Sound Power level

NOTE

- Specifications may be subject to change without prior notice
 - Sound power level is an absolute value that a sound source generates.
 - dBA = A-weighted sound power level.
 - Reference power : 1pW.
 - Measured according to ISO 3741.

Model	Power (dBA)
AE200*NWMEG/EU + AE050CXYDEK/EU	40
AE200*NWMEG/EU + AE080CXYDEK/EU	40
AE200*NWMEG/EU + AE120CXYDEK/EU	44
AE200*NWMEG/EU + AE160CXYDEK/EU	44

1) AE200*NWMEG/EU+AE050CXYDEK/EU

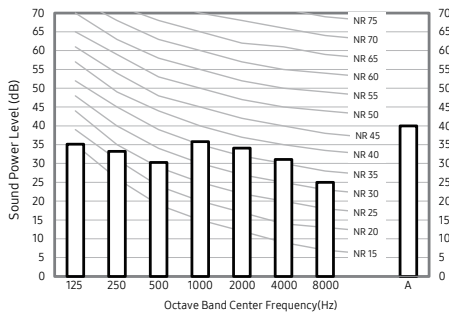

2) AE200*NWMEG/EU+AE080CXYDEK/EU

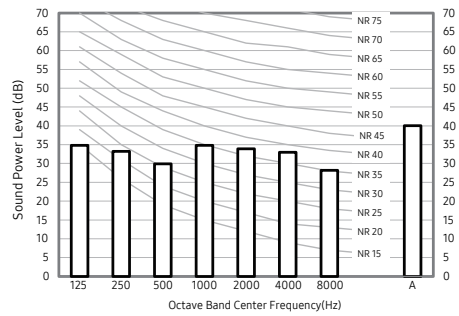

3) AE200*NWMEG/EU+AE120CXYDEK/EU

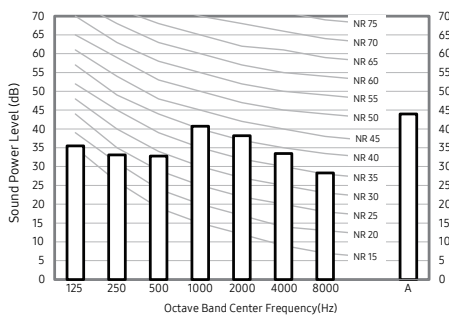

4) AE200*NWMEG/EU+AE160CXYDEK/EU

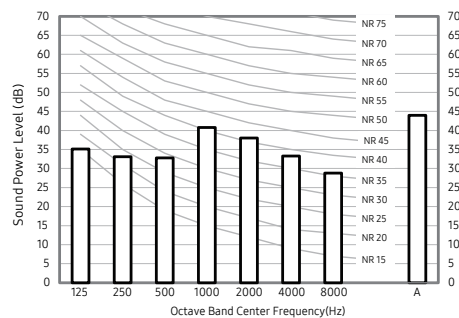

3. Tank integrated hydro unit

3-4. Sound data

Sound Power level

NOTE

- Specifications may be subject to change without prior notice
 - Sound power level is an absolute value that a sound source generates.
 - dBA = A-weighted sound power level.
 - Reference power : 1pW.
 - Measured according to ISO 3741.

Model	Power (dBA)
AE260*NWMEG/EU + AE080CXYDEK/EU	40
AE260*NWMEG/EU + AE120CXYDEK/EU	44
AE260*NWMEG/EU + AE160CXYDEK/EU	44

1) AE260*NWMEG/EU+AE080CXYDEK/EU

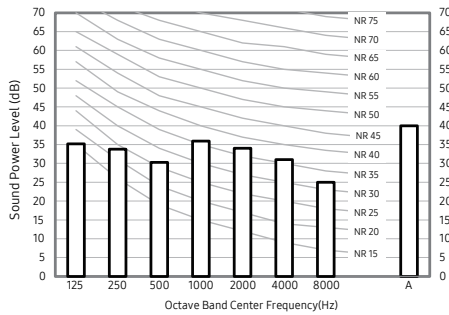

2) AE260*NWMEG/EU+AE120CXYDEK/EU

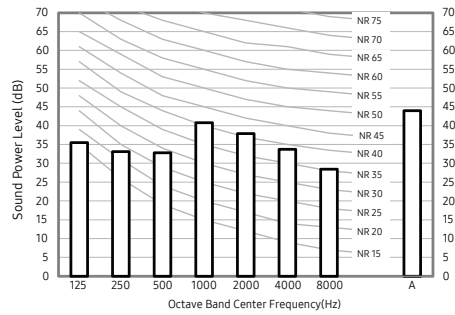

3) AE260*NWMEG/EU+AE160CXYDEK/EU

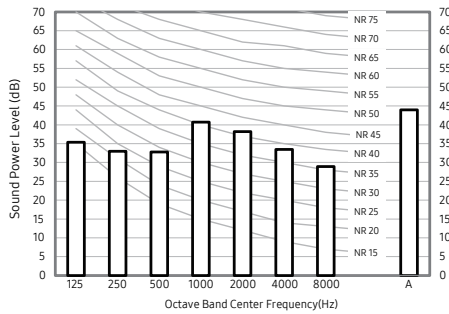

3. Tank integrated hydro unit

3-4. Sound data

Sound Power level

NOTE

- Specifications may be subject to change without prior notice
 - Sound power level is an absolute value that a sound source generates.
 - dBA = A-weighted sound power level.
 - Reference power : 1pW.
 - Measured according to ISO 3741.

Model	Power (dBA)
AE260*NWMEG/EU + AE080CXYDEK/EU	40
AE260*NWMEG/EU + AE120CXYDEK/EU	44
AE260*NWMEG/EU + AE160CXYDEK/EU	44

1) AE260*NWMGG/EU+AE080CXYDGK/EU

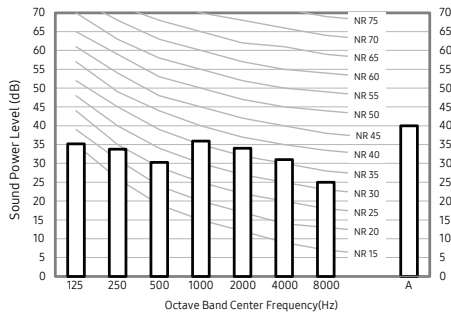

2) AE260*NWMGG/EU+AE120CXYDGK/EU

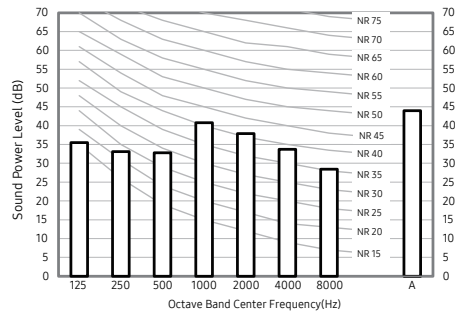

3) AE260*NWMGG/EU+AE160CXYDGK/EU

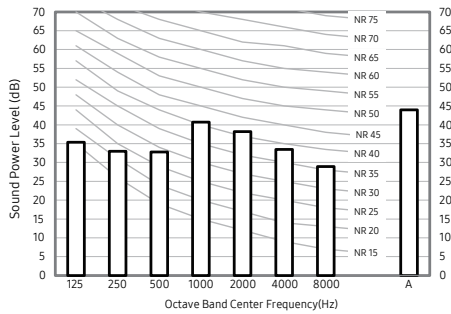

3. Tank integrated hydro unit

3-5. Piping diagram

AE200/260CNWM*G/EU

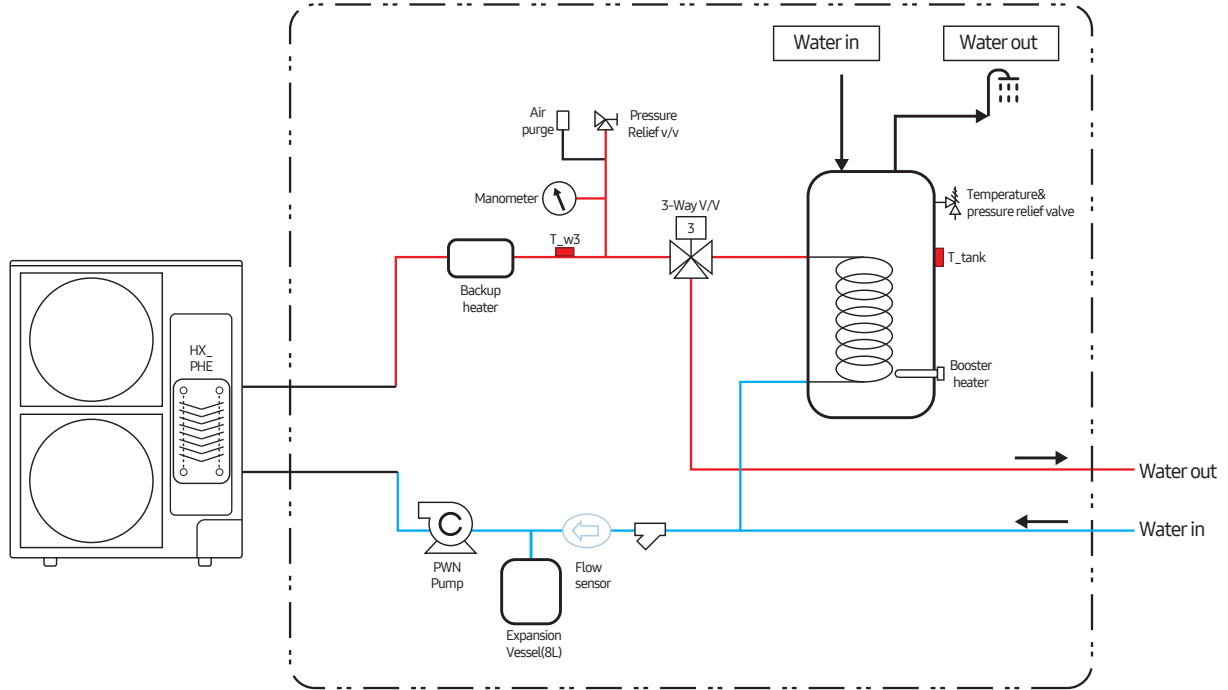

4. Control Kit

4-1. Specifications

Model Name			MIM-E03CN	MIM-E03EN
Compatible with		-	EHS Mono (Standard, HT)	EHS Mono (Standard, HT)
Power Supply		Ø, #, V, Hz	1, 2, 220-240, 50	1, 2, 220-240, 50
External Dimension	Net Weight	kg	3.50	3.50
	Shipping Weight	kg	6.90	6.90
	Shipping Dimensions (WxHxD)	mm	329 x 439 x 168	329 x 439 x 168
External Control	Booster Heater	-	AC 230V (Max 20A)	AC 230V (Max 20A)
	Back up Heater (/Boiler)	-	AC 230V (Max 10mA)	AC 230V (Max 10mA)
	Water Pump	-	AC 230V (Max 0.5A)	AC 230V (Max 0.5A)
	2way(or 3way) Valve	-	AC 230V (Max 22mA)	AC 230V (Max 22mA)
	Room Thermostat	-	AC 230V (Max 22mA)	AC 230V (Max 22mA)
	Solar Pump	-	AC 230V (Max 10mA)	AC 230V (Max 10mA)
	Inverter Pump	-	AC 230V (Max 0.5A)	AC 230V (Max 0.5A)
	3way Mixing Valve	-	AC 230V (Max 22mA)	AC 230V (Max 22mA)
Fuction	SG Ready (Smart Grid Ready)	-	X	○
	Multi zone (2 zone)	-	X	○

4. Control Kit

4-1. Specifications

Model Name		Indoor Unit			MIM-E03CN / MIM-E03EN		MIM-E03CN / MIM-E03EN		
		Outdoor Unit			AE050CXYDEK/EU		AE080CXYDEK/EU		
Power Supply				Φ, #, V, Hz	1, 2, 220~240, 50		1, 2, 220~240, 50		
System	Mode				-	Heat Pump (A2W)		Heat Pump (A2W)	
	Performance	Capacity	Heating	A2W Condition #1. (A7/W35) ^{1)*}	W	5,000	8,000		
				A2W condition #2	Btu/h	17,100	27,300		
				A2W condition #3	W	5,000	8,000		
				A2/W35 ^{4)*}		5,000	8,000		
				A-7/W35 ^{4)*}		5,000	8,000		
			Cooling	A2W Condition #1. (A35/W18) ^{1)*}	W	5,000	8,000		
				A2W condition #2	Btu/h	17,100	27,300		
					W	3,900	5,700		
					W	980	1,630		
					W	1,320	2,160		
	Power	Power Input	Heating	A2W Condition #1. (A7/W35) ^{1)*}	W	1,610	2,670		
				A2W condition #2		1,160	1,900		
				A2/W35 ^{4)*}		1,670	2,670		
				A-7/W35 ^{4)*}					
			Cooling	A2W Condition #1. (A35/W18) ^{1)*}	W	1,280	2,050		
				A2W condition #2		1,279	1,900		
						4.63	7.70		
						6.05	9.69		
						6.24	10.21		
	Current Input	Heating	A2W Condition #1.	A	7.61	12.62			
					6.05	9.69			
		Cooling	A2W condition #2	A	16.1	26.0			
					17.6	28.6			
	Current	MCA	A	17.6	28.6				
		MFA	A						
	Efficiency	COP (Nominal Heating) A2W condition #1				5.10	4.91		
		EER (Nominal Cooling) A2W condition #1				3.91	3.90		
		EER (Nominal Cooling) A2W condition #2				3.05	3.00		
		COP			A2W condition #2	W/W	3.80	3.70	
					A2W condition #3		3.10	3.00	
					A2/W35 ^{4)*}		4.30	4.20	
					A-7/W35 ^{4)*}		3.00	3.00	
		PdesignH (LWT 35°C)				5,500	8,000		
		PdesignH (LWT 55°C)				5,500	8,000		
		SCOP (35°C)				5.10	4.85		
		SCOP (55°C)				3.60	3.55		
		SCOP Class (35°C)				A+++	A+++		
SCOP Class (55°C)				A++	A++				
SEER				4.20	4.30				
Water Connections	Water Flow Rate (Nominal)		Heating	LPM	14.4	23.1			
			Cooling	LPM	14.4	21.6			
	Water Flow Rate		Min	LPM	7	7			
			Max	LPM	48	48			
	Water Pressure (Max)			bar	3	3			
	Leaving Water Temperature	Min.	Heating	°C	15	15			
				°C	75	75			
Max.		Cooling	°C	5	5				
			°C	25	25				
Refrigerant	Type			-	R290	R290			
	Factory Charging			g	630	870			
	Control Method			tCO ₂ e	0.00189	0.00255			
Outdoor Unit	Type			-	EEV	EEV			
	Model Name			-	Rotary	Rotary			
				-	UF8HC5180FEU	UF5HC5260FEX			
	Oil	Type		-	Mineral	Mineral			
		Initial Charge		cc	590	850			
	Quantity			EA	1	1			
	Output			W	1,551	2,236			
Starting method			-	Inverter driven	Inverter driven				
Motor	Crankcase heater	Output	W	-	-				

4. Control Kit

4-1. Specifications

Model Name		Indoor Unit		MIM-E03CN / MIM-E03EN	MIM-E03CN / MIM-E03EN	
		Outdoor Unit		AE050CXYDEK/EU	AE080CXYDEK/EU	
Outdoor Unit	Heat exchanger	Length		mm	986/957	986/957/928
		Rows	Quantity	EA	2	3
		Fin pitch		mm	1.5	1.5
		Passes	Quantity	EA	6-6	9-9
		Face area		m ²	0.79	0.79
		Stages	Quantity	EA	38	38
		Empty tubeplate hole	Quantity	EA	-	-
		Tube type		-	Φ7	Φ7
		Fin	Type	-	Corrugate	Corrugate
			Treatment	-	Anti Salt	Anti Salt
	Fan	Type		-	Propeller Fan	Propeller Fan
		Discharge direction		-	Horizontal	Horizontal
		Air Flow Rate	Heating	m ³ /min	52	65
			Cooling	m ³ /min	55	69
		Quantity		EA	1	1
	Fan motor	Quantity		EA	1	1
		Model		-	FMDC531SSJ	FMDC531SSJ
		Output		W	125	125
		Drive		-	Direct drive	Direct drive
		Speed	Steps	-	-	-
			Heating	rpm	550	720
	Cooling		rpm	580	760	
	Sound Level	Sound Pressure Level	Heating	dB(A)	41	45
			Cooling	dB(A)	41	45
			Night Mode(3m)	dB(A)	35	35
		Sound Power Level	Heating	dB(A)	55	59
	Cooling		dB(A)	55	59	
	Connections	Water pipe	Inlet	-	BSPP male 1"	BSPP male 1"
			Outlet	-	BSPP male 1"	BSPP male 1"
	Casing	Color	-	Shadow Gray	Shadow Gray	
		Material	-	GI-SGCC	GI-SGCC	
	Packing	Material	-	EPS/BOX	EPS/BOX	
		Weight	kg	13	13	
	External Dimension	Net Weight		kg	86	98
		Shipping Weight		kg	96	108
		Net Dimensions (WxHxD)		mm	998x850x500	998x850x500
		Shipping Dimensions (WxHxD)		mm	1,070x1,018x630	1,070x1,018x630
	Operating Temp. Range	Heating	Min.	°C	-25	-25
			Max.	°C	35	35
		Cooling	Min.	°C	10	10
Max.			°C	46	46	
D.Hot Water		Min.	°C	-25	-25	
		Max.	°C	43	43	

NOTE

- Specifications may be subject to change without prior notice.
- 1) A2W Condition #1 : (Heating) Water In/Out 30°C/35°C, Outdoor Air 7°C[DB]/6°C[WB];
(Cooling) Water In/Out 23°C/18°C, Outdoor Air 35°C[DB].
- 2) A2W Condition #2 : (Heating) Water In/Out 40°C/45°C, Outdoor Air 7°C[DB]/6°C[WB];
(Cooling) Water In/Out 12°C/7°C, Outdoor Air 35°C[DB].
- 3) A2W Condition #3 : (Heating) Water In/Out 47°C/55°C, Outdoor Air 7°C[DB]/6°C[WB].
- 4) A2W Condition : (A2W35) Water In/Out -/35°C, Outdoor Air 2°C[DB]/1°C[WB];
(A-7/W35) Water In/Out -/35°C, Outdoor Air -7°C[DB]/-(※ Peak Capacity)
- 5) Select wire size based on the value of MCA.
- 6) Soundpressure level is obtained in an anechoic room.
 - Sound pressure level is a relative value, depending on the distance and acoustic environment.
 - Sound pressure level may differ depending on operation condition.
 - dBA = A-weighted sound pressure level
 - Reference acoustic pressure 0 dB = 20uPa
- 7) Sound power level is an absolute value that a sound source generates.
 - dBA = A-weighted Sound power level
 - Reference power : 1pW
 - Measured according to ISO 3741
- 8) These products contain R290 (GWP=3) which is fluorinated greenhouse gas.
- 9) The system is operated in (-25°C ≤ Outdoor temp. < -20°C) condition, but no guarantee of capacity.
- 10) The system is operated by only Booster Heater in special condition (35 °C < Outdoor temp. ≤ 43°C).

4. Control Kit

4-1. Specifications

Model Name		Indoor Unit			MIM-E03CN / MIM-E03EN	MIM-E03CN / MIM-E03EN		
		Outdoor Unit			AE120CXYDEK/EU	AE160CXYDEK/EU		
Power Supply				Φ, #, V, Hz	1, 2, 220~240, 50	1, 2, 220~240, 50		
System	Mode			-	Heat Pump (A2W)	Heat Pump (A2W)		
	Performance	Capacity	Heating	A2W Condition #1. (A7/W35) ^{1)*}	W	12,000	16,000	
				A2W condition #2	Btu/h	40,900	54,600	
				A2W condition #3	W	12,000	16,000	
				A2/W35 ^{4)*}		12,000	16,000	
				A-7/W35 ^{4)*}		12,000	16,000	
			Cooling	A2W Condition #1. (A35/W18) ^{1)*}	W	12,000	14,000	
				A2W condition #2	Btu/h	40,900	47,800	
						W	9,000	10,400
						W	2,500	3,550
						W	3,240	4,570
	Power	Power Input	Heating	A2W Condition #1. (A7/W35) ^{1)*}	W	4,000	5,520	
				A2W condition #2		2,790	4,100	
				A2W condition #3		4,000	5,710	
				A2/W35 ^{4)*}		3,000	3,680	
				A-7/W35 ^{4)*}		3,103	3,586	
			Cooling	A2W Condition #1. (A35/W18) ^{1)*}	W	11.81	16.78	
				A2W condition #2		14.18	17.39	
						15.31	21.60	
						18.90	26.09	
						32.0	32.0	
	Current Input	Heating	A2W Condition #1.		A	35.2	35.2	
			A2W condition #2			A	32.0	32.0
		Cooling	A2W Condition #1.		A	32.0	32.0	
			A2W condition #2			A	35.2	35.2
	Current	MCA		A	32.0	32.0		
		MFA		A	35.2	35.2		
	Efficiency	COP (Nominal Heating) A2W condition #1				4.80	4.51	
		EER (Nominal Cooling) A2W condition #1				4.00	3.80	
		EER (Nominal Cooling) A2W condition #2				2.90	2.90	
		COP			A2W condition #2	W/W	3.70	3.50
					A2W condition #3		3.00	2.90
					A2/W35 ^{4)*}		4.30	3.90
					A-7/W35 ^{4)*}		3.00	2.80
		PdesignH (LWT 35°C)				12,000	15,500	
		PdesignH (LWT 55°C)				12,000	14,500	
		SCOP (35°C)				4.90	4.70	
		SCOP (55°C)				3.65	3.55	
		SCOP Class (35°C)				A+++	A+++	
SCOP Class (55°C)				A++	A++			
SEER				4.80	5.00			
Water Connections	Water Flow Rate (Nominal)		Heating	LPM	34.6	46.2		
			Cooling	LPM	34.6	40.4		
	Water Flow Rate		Min	LPM	7	7		
			Max	LPM	58	58		
	Water Pressure (Max)			bar	3	3		
	Leaving Water Temperature	Min.	Heating	°C	15	15		
				°C	75	75		
		Max.	Cooling	°C	5	5		
°C				25	25			
Refrigerant	Type			-	R290	R290		
	Factory Charging			g	1,250	1,250		
				tCO ₂ e	0.00375	0.00375		
	Control Method			-	EEV	EEV		
Outdoor Unit	Compressor	Type			-	Scroll	Scroll	
		Model Name			-	DS4HC5066FNA	DS4HC5066FNA	
		Oil	Type		-	Kixx RF P85	Kixx RF P85	
			Initial Charge		cc	1,100	1,100	
		Quantity			EA	1	1	
		Output			W	3,803	3,803	
		Starting method			-	Inverter driven	Inverter driven	
		Motor	Crankcase heater	Output	W	-	-	

4. Control Kit

4-1. Specifications

Model Name		Indoor Unit		MIM-E03CN / MIM-E03EN	MIM-E03CN / MIM-E03EN	
		Outdoor Unit		AE120CXYDEK/EU	AE160CXYDEK/EU	
Outdoor Unit	Heat exchanger	Length		mm	1,239/1,210/1,182	1,239/1,210/1,182
		Rows	Quantity	EA	3	3
		Fin pitch		mm	1.5	1.5
		Passes	Quantity	EA	22-12	22-12
		Face area		m ²	1.17	1.17
		Stages	Quantity	EA	46	46
		Empty tubeplate hole	Quantity	EA	-	-
		Tube type		-	Φ7	Φ7
		Fin	Type	-	Corrugate	Corrugate
			Treatment	-	Anti Salt	Anti Salt
	Fan	Type		-	Propeller Fan	Propeller Fan
		Discharge direction		-	Horizontal	Horizontal
		Air Flow Rate	Heating	m ³ /min	95	95
			Cooling	m ³ /min	90	90
		Quantity	EA	1	1	
	Fan motor	Quantity		EA	1	1
		Model		-	SIC-88FWJ-F1122-1	SIC-88FWJ-F1122-1
		Output		W	122	122
		Drive		-	Direct drive	Direct drive
		Speed	Steps	-	-	-
			Heating	rpm	590	590
	Cooling		rpm	560	580	
	Sound	Sound Pressure	Heating	dB(A)	47	51
			Cooling	dB(A)	47	51
			Night Mode(3m)	dB(A)	35	35
		Sound Power	Heating	dB(A)	60	65
	Cooling		dB(A)	60	65	
	Connections	Water pipe	inlet	-	BSP male 1"	BSP male 1"
			outlet	-	BSP male 1"	BSP male 1"
	Casing	Color	-	Shadow Gray	Shadow Gray	
		Material	-	GI-SGCC	GI-SGCC	
	Packing	Material	-	EPS/BOX	EPS/BOX	
		Weight	kg	20	20	
	External Dimension	Net Weight		kg	140	140
		Shipping Weight		kg	154	154
		Net Dimensions (WxHxD)		mm	1,270x1,018x530	1,270x1,018x530
		Shipping Dimensions (WxHxD)		mm	1,330x1,226x630	1,330x1,226x630
	Operating Temp. Range	Heating	Min.	°C	-25	-25
			Max.	°C	35	35
		Cooling	Min.	°C	10	10
Max.			°C	46	46	
D.Hot Water		Min.	°C	-25	-25	
		Max.	°C	43	43	

NOTE

- Specifications may be subject to change without prior notice.
- 1) A2W Condition #1 : (Heating) Water In/Out 30°C/35°C, Outdoor Air 7°C[DB]/6°C[WB];
(Cooling) Water In/Out 23°C/18°C, Outdoor Air 35°C[DB].
- 2) A2W Condition #2 : (Heating) Water In/Out 40°C/45°C, Outdoor Air 7°C[DB]/6°C[WB];
(Cooling) Water In/Out 12°C/7°C, Outdoor Air 35°C[DB].
- 3) A2W Condition #3 : (Heating) Water In/Out 47°C/55°C, Outdoor Air 7°C[DB]/6°C[WB].
- 4) A2W Condition : (A2W35) Water In/Out -/35°C, Outdoor Air 2°C[DB]/1°C[WB];
(A-7/W35) Water In/Out -/35°C, Outdoor Air -7°C[DB]/-(※ Peak Capacity)
- 5) Select wire size based on the value of MCA.
- 6) Soundpressure level is obtained in an anechoic room.
 - Sound pressure level is a relative value, depending on the distance and acoustic environment.
 - Sound pressure level may differ depending on operation condition.
 - dBA = A-weighted sound pressure level
 - Reference acoustic pressure 0 dB = 20uPa
- 7) Sound power level is an absolute value that a sound source generates.
 - dBA = A-weighted Sound power level
 - Reference power : 1pW
 - Measured according to ISO 3741
- 8) These products contain R290 (GWP=3) which is fluorinated greenhouse gas.
- 9) The system is operated in (-25°C ≤ Outdoor temp. < -20°C) condition, but no guarantee of capacity.
- 10) The system is operated by only Booster Heater in special condition (35 °C < Outdoor temp. ≤ 43°C).

4. Control Kit

4-1. Specifications

Model Name		Indoor Unit			MIM-E03CN/MIM-E03EN	MIM-E03CN/MIM-E03EN	MIM-E03CN/MIM-E03EN		
		Outdoor Unit			AE080CXYDGK/EU	AE120CXYDGK/EU	AE160CXYDGK/EU		
Power Supply				Φ, #, V, Hz	3, 4, 380~415, 50	3, 4, 380~415, 50	3, 4, 380~415, 50		
System	Mode			-	Heat Pump (A2W)	Heat Pump (A2W)	Heat Pump (A2W)		
	Performance	Capacity	Heating	A2W Condition #1. (A7/W35) ^{1)*}	W	8,000	12,000	16,000	
				Btu/h	27,300	40,900	54,600		
				A2W condition #2	W	8,000	12,000	16,000	
				A2W condition #3		8,000	12,000	16,000	
				A2/W35 ^{4)*}		8,000	12,000	16,000	
			A-7/W35 ^{4)*}	8,000	12,000	16,000			
			Cooling	A2W Condition #1. (A35/W18) ^{1)*}	W	8,000	12,000	14,000	
				Btu/h	27,300	40,900	47,800		
			A2W condition #2	W	5,700	9,000	10,400		
			Power	Power Input	Heating	A2W Condition #1. (A7/W35) ^{1)*}	W	1,630	2,500
	A2W condition #2	2,160				3,240		4,570	
	A2W condition #3	2,670				4,000		5,520	
	A2/W35 ^{4)*}	1,900				2,790		4,100	
	A-7/W35 ^{4)*}	2,670				4,000		5,710	
	Cooling	A2W Condition #1. (A35/W18) ^{1)*}			W	2,050	3,000	3,680	
		A2W condition #2				1,900	3,103	3,714	
	Current Input	Heating			A2W Condition #1.	A	2.56	3.92	5.57
							Cooling	3.22	4.71
		Cooling			A2W condition #2	A	3.39	5.08	7.17
				4.19			6.28	8.66	
	Current	MCA		A	16.1	16.1	16.1		
		MFA		A	17.7	17.7	17.7		
	Efficiency	COP (Nominal Heating) A2W condition #1				4.91	4.80	4.51	
		EER (Nominal Cooling) A2W condition #1				3.90	4.00	3.80	
		EER (Nominal Cooling) A2W condition #2				3.00	2.90	2.90	
		COP			A2W condition #2	W/W	3.70	3.70	3.50
					A2W condition #3		3.00	3.00	2.90
					A2/W35 ^{4)*}		4.20	4.30	3.90
					A-7/W35 ^{4)*}		3.00	3.00	2.80
		PdesignH (LWT 35°C)				8,000	12,000	15,500	
		PdesignH (LWT 55°C)				8,000	12,000	15,500	
		SCOP (35°C)				4.85	4.90	4.70	
		SCOP (55°C)				3.55	3.65	3.55	
		SCOP Class (35°C)				A+++	A+++	A+++	
		SCOP Class (55°C)				A++	A++	A++	
		SEER				4.30	4.80	5.00	
		Water Connections	Water Flow Rate (Nominal)		Heating	LPM	23.1	34.6	46.2
	Cooling				LPM	21.6	34.6	40.4	
	Water Flow Rate		Min	LPM	7	7	7		
			Max	LPM	48	58	58		
	Water Pressure (Max)			bar	3	3	3		
	Leaving Water Temperature		Min.	Heating	°C	15	15	15	
					°C	75	75	75	
			Max.	Cooling	°C	5	5	5	
		°C			25	25	25		
	Refrigerant	Type			-	R290	R290	R290	
		Factory Charging			g	870	1,250	1,250	
					tCO ₂ e	0.00255	0.00375	0.00375	
		Control Method			-	EEV	EEV	EEV	
	Outdoor Unit	Compressor	Type			-	Rotary	Scroll	Scroll
			Model Name			-	UF5HC5260FEX	DS4HC5066FNA	DS4HC5066FNA
			Oil		Type	-	Mineral	Kixx RF P85	Kixx RF P85
					Initial Charge	cc	850	1,100	1,100
			Quantity			EA	1	1	1
			Output			W	2,236	3,803	3,803
			Starting method			-	Inverter driven	Inverter driven	Inverter driven
			Motor	Crankcase heater	Output	W	-	-	-

4. Control Kit

4-1. Specifications

Model Name		Indoor Unit		MIM-E03CN/MIM-E03EN	MIM-E03CN/MIM-E03EN	MIM-E03CN/MIM-E03EN	
		Outdoor Unit		AE080CXYDGK/EU	AE120CXYDGK/EU	AE160CXYDGK/EU	
Outdoor Unit	Heat exchanger	Length		mm	986/957/928	1,239/1,210/1,182	1,239/1,210/1,182
		Rows	Quantity	EA	3	3	3
		Fin pitch		mm	1.5	1.5	1.5
		Passes	Quantity	EA	9-9	22-12	22-12
		Face area		m ²	0.79	1.17	1.17
		Stages	Quantity	EA	38	46	46
		Empty tubeplate hole	Quantity	EA	-	-	-
		Tube type		-	Φ7	Φ7	Φ7
		Fin	Type	-	Corrugate	Corrugate	Corrugate
			Treatment	-	Anti Salt	Anti Salt	Anti Salt
	Fan	Type		-	Propeller Fan	Propeller Fan	Propeller Fan
		Discharge direction		-	Horizontal	Horizontal	Horizontal
		Air Flow Rate	Heating	m ³ /min	65	95	95
			Cooling	m ³ /min	69	90	94
		Quantity		EA	1	1	1
	Fan motor	Quantity		EA	1	1	1
		Model		-	FMDC531SSJ	SIC-88FWJ-F1122-1	SIC-88FWJ-F1122-1
		Output		W	125	122	122
		Drive		-	Direct drive	Direct drive	Direct drive
		Speed	Steps	-	-	-	-
			Heating	rpm	720	590	590
	Cooling		rpm	760	560	580	
	Sound Level	Sound Pressure Level	Heating	dB(A)	45	47	51
			Cooling	dB(A)	45	47	51
			Night Mode(3m)	dB(A)	35	35	35
		Sound Power Level	Heating	dB(A)	59	60	65
	Cooling		dB(A)	59	60	65	
	Connections	Water pipe	Inlet	-	BSPP male 1"	BSPP male 1"	BSPP male 1"
			Outlet	-	BSPP male 1"	BSPP male 1"	BSPP male 1"
	Casing	Color	-	Shadow Gray	Shadow Gray	Shadow Gray	
		Material	-	GI-SGCC	GI-SGCC	GI-SGCC	
	Packing	Material	-	EPS/BOX	EPS/BOX	EPS/BOX	
		Weight	kg	13	20	20	
	External Dimension	Net Weight		kg	98	140	140
		Shipping Weight		kg	108	154	154
		Net Dimensions (WxHxD)		mm	998x850x500	1,270x1,018x530	1,270x1,018x530
		Shipping Dimensions (WxHxD)		mm	1,070x1,018x630	1,330x1,226x630	1,330x1,226x630
	Operating Temp. Range	Heating	Min.	°C	-25	-25	-25
			Max.	°C	35	35	35
		Cooling	Min.	°C	10	10	10
Max.			°C	46	46	46	
D.Hot Water		Min.	°C	-25	-25	-25	
		Max.	°C	43	43	43	

NOTE

- Specifications may be subject to change without prior notice.
- 1) A2W Condition #1 : (Heating) Water In/Out 30°C/35°C, Outdoor Air 7°C[DB]/6°C[WB]; (Cooling) Water In/Out 23°C/18°C, Outdoor Air 35°C[DB].
- 2) A2W Condition #2 : (Heating) Water In/Out 40°C/45°C, Outdoor Air 7°C[DB]/6°C[WB]; (Cooling) Water In/Out 12°C/7°C, Outdoor Air 35°C[DB].
- 3) A2W Condition #3 : (Heating) Water In/Out 47°C/55°C, Outdoor Air 7°C[DB]/6°C[WB].
- 4) A2W Condition : (A2W35) Water In/Out -/35°C, Outdoor Air 2°C[DB]/1°C[WB]; (A-7/W35) Water In/Out -/35°C, Outdoor Air -7°C[DB]/-(※ Peak Capacity)
- 5) Select wire size based on the value of MCA.
- 6) Soundpressure level is obtained in an anechoic room.
 - Sound pressure level is a relative value, depending on the distance and acoustic environment.
 - Sound pressure level may differ depending on operation condition.
 - dBA = A-weighted sound pressure level
 - Reference acoustic pressure 0 dB = 20uPa
- 7) Sound power level is an absolute value that a sound source generates.
 - dBA = A-weighted Sound power level
 - Reference power : 1pW
 - Measured according to ISO 3741
- 8) These products contain R290 (GWP=3) which is fluorinated greenhouse gas.
- 9) The system is operated in (-25°C ≤ Outdoor temp. < -20°C) condition, but no guarantee of capacity.
- 10) The system is operated by only Booster Heater in special condition (35 °C < Outdoor temp. ≤ 43°C).

4. Control Kit

4-2. Dimensional drawing

Product line-up and accessories

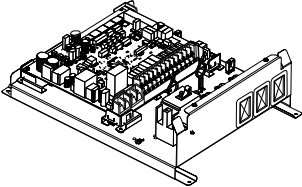
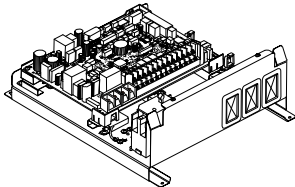
Control kit		
Chassis		
Model name	MIM-E03CN	MIM-E03EN

Main component

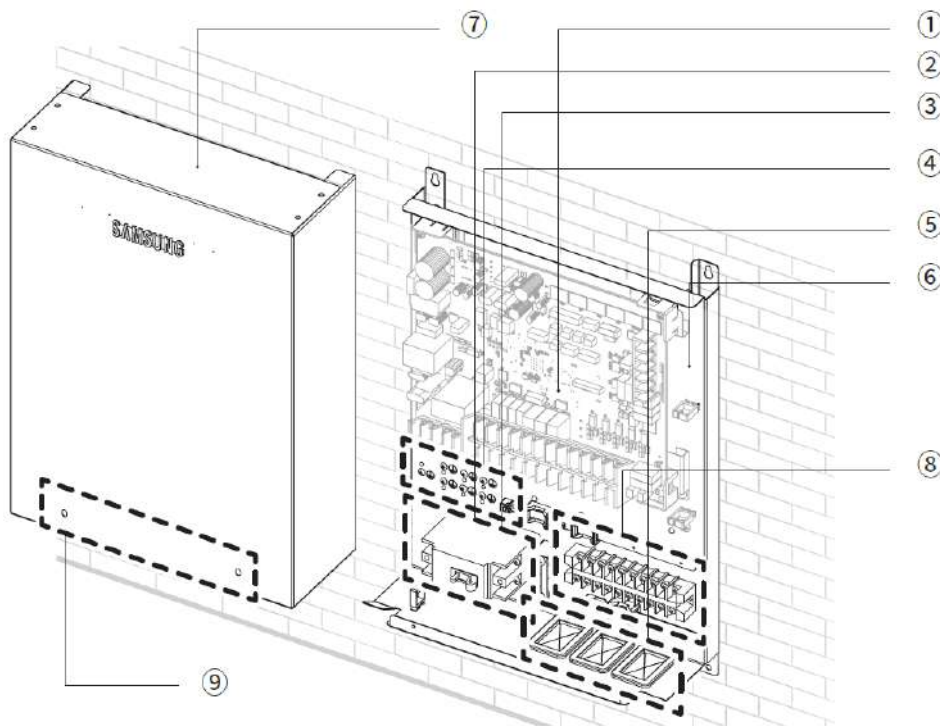

(Unit : EA)

No.	Part	Description	
		MIM-E03CN	MIM-E03EN
①	Main PBA	1	1
②	ELCB - Rated current : 30A	1	1
③	ELCB - Leakage current : 30mA	1	1
④	Grounding screw	7	7
⑤	Rubber	3	3
⑥	Base plate	1	1
⑦	Top cover plate	1	1
⑧	Terminal Block (10p)	-	1
⑨	Case screw	2	2

4. Control Kit

4-3. Electrical wiring diagram

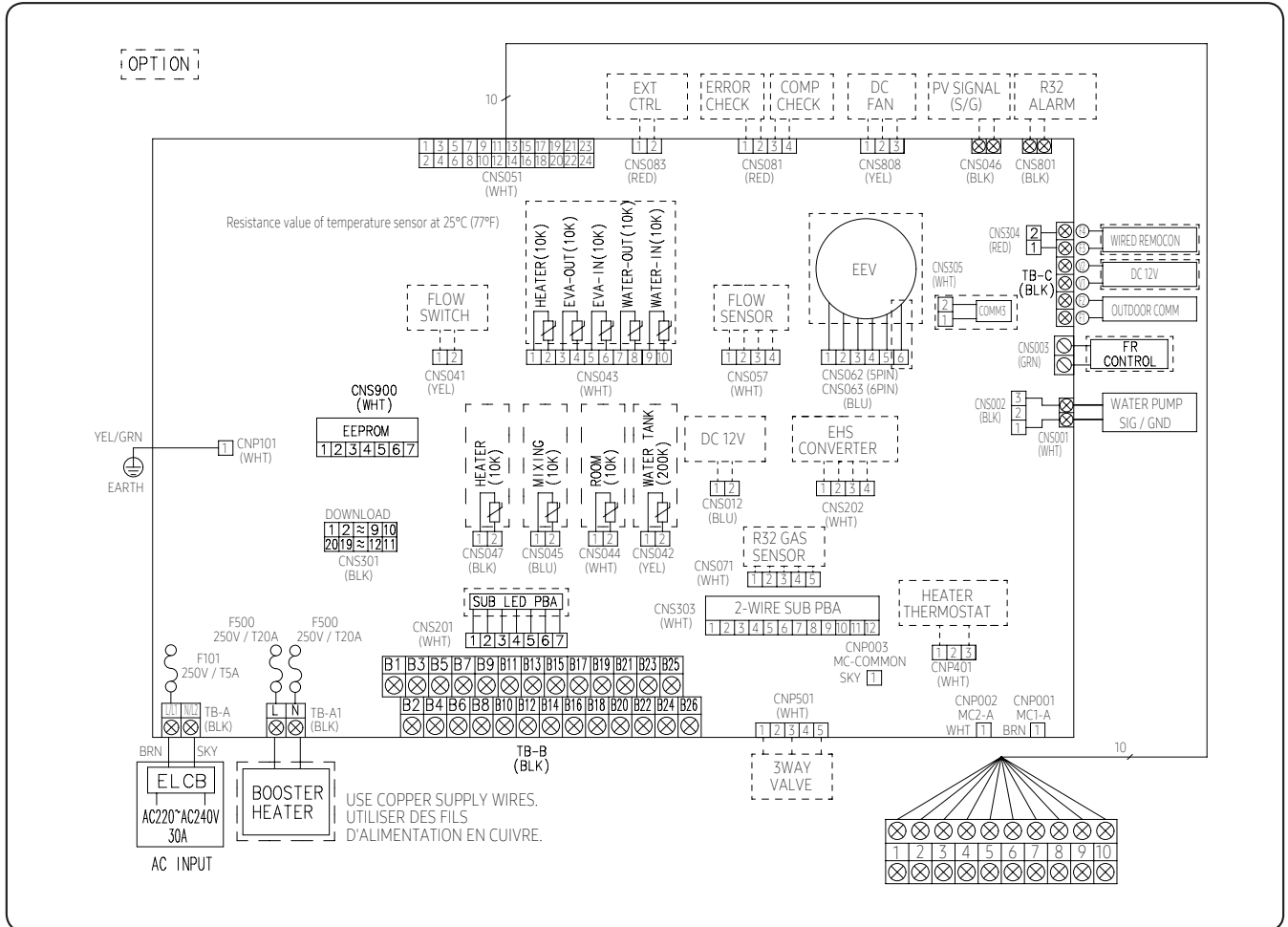

NOTES

1. It does not support external input(CNS083)/output(CNS081) signal function.
2. MIM-E03CN model does not support CNS051 function. Therefore there is no zone control via wired remote controller or SmartGrid ready functions available.

5. Installation

Tank integrated hydro unit

* The below examples are for illustration purposes only.

Application 1: Space heating + water heating

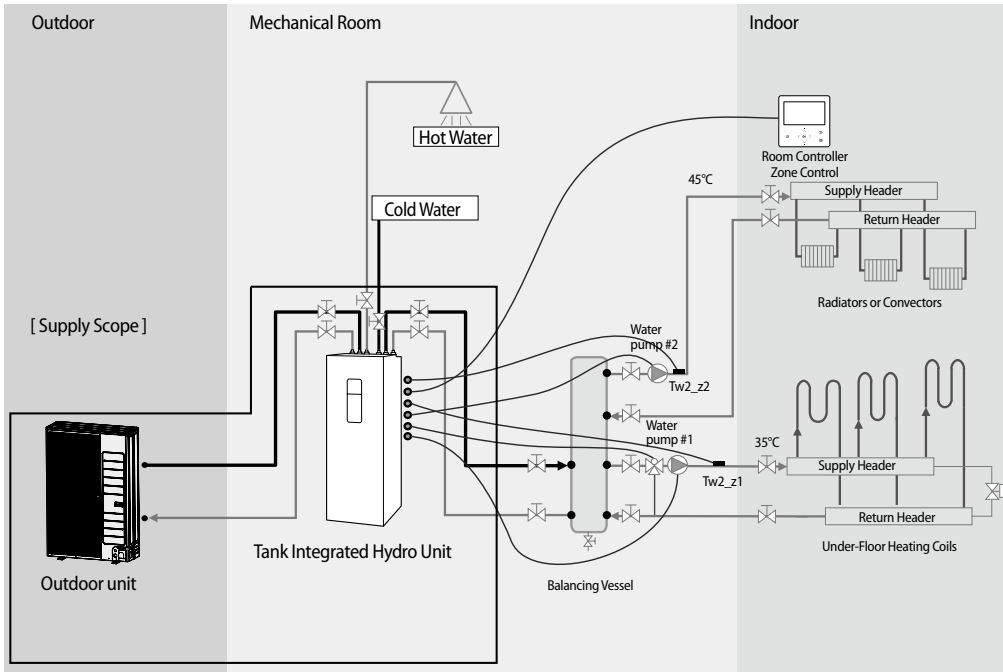

Application 2: Hybrid application(backup boiler)

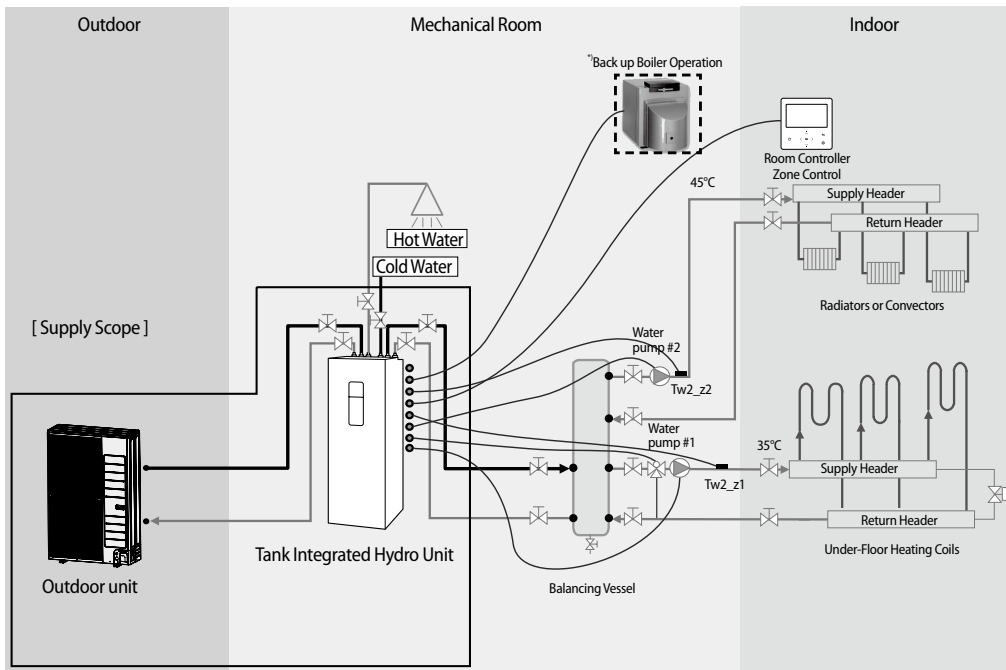

*) We control only the on / off signal of backup boiler according to outdoor temperature. Backup boiler should be installed with own device according to the field condition.



- Samsung has not responsible for performance and stability of backup boiler.
- Water quality must be according to EN directive 98/83 EC.

5. Installation

Tank integrated hydro unit

Wiring work

* When you use inlet hole through the cabinet top positions for power/communication wires, please fix the wire by using mount tie of the cabinet right.

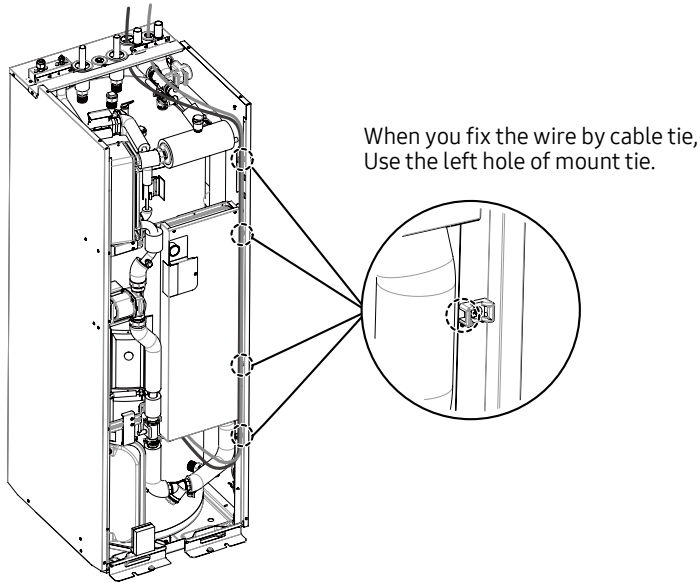

2 wires for communication cable

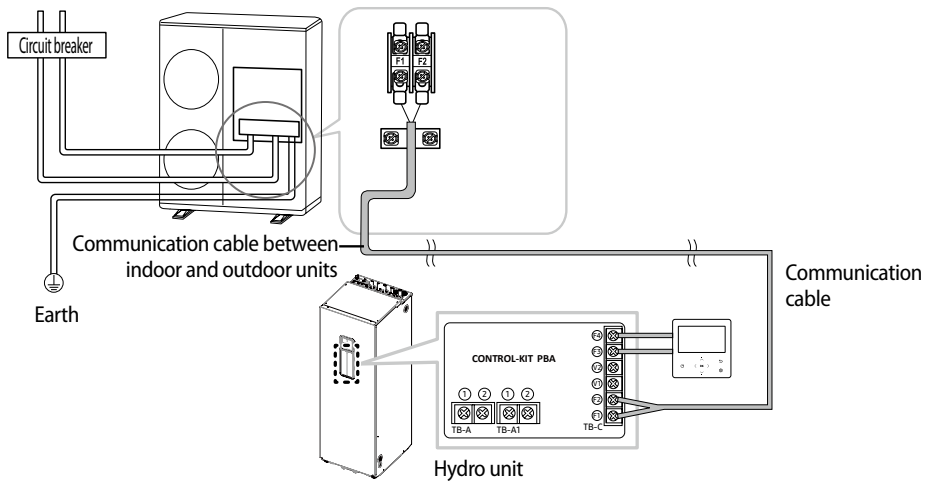

Communication cable connection

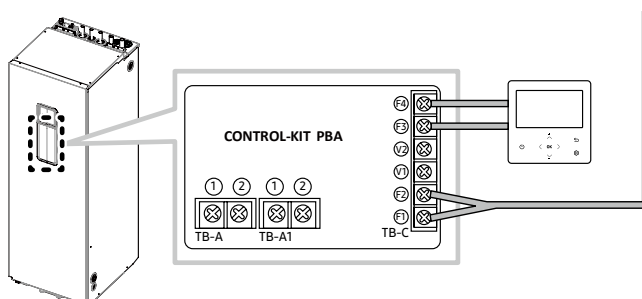

5. Installation

Tank integrated hydro unit

1.1 phase product

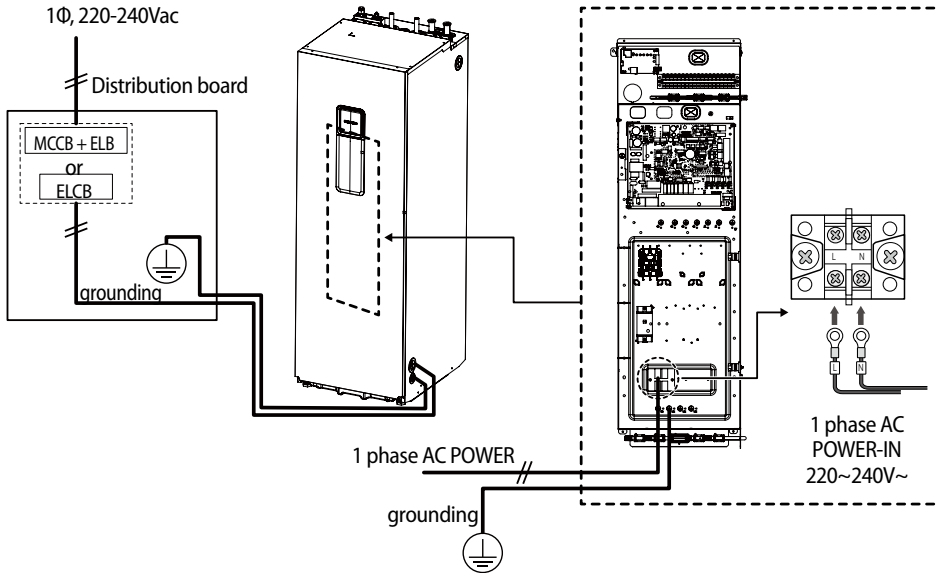

2. 3 phase product

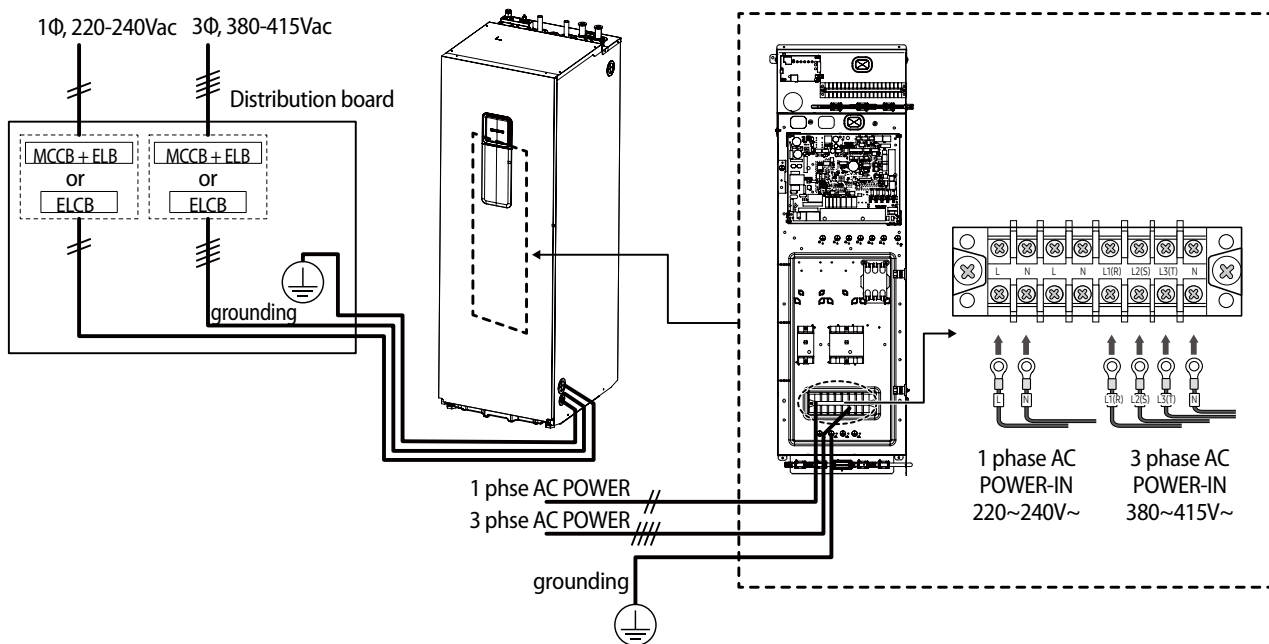

- If the supply cable is damaged, it must be replaced by a special cable or assembly available from the manufacturer or installer.
- Circuit Breaker (ELCB, ELB, MCCB etc.) for outdoor and indoor units shall be installed by installers because they are not sub-parts in the units. But you don't need to install for hydro unit (Built-in ELCB).
- It cause damage to chassis, PCB parts if the main power is not connected correctly. You should make certain that R, S, T is connected correctly before turning on the main power. (3 phase models only)

* ELCB : Earth leakage circuit breaker
ELB : Earth leakage breaker
MCCB : Molded case circuit breaker

5. Installation

Tank integrated hydro unit

Mixing Valve

Installation of mixing valve

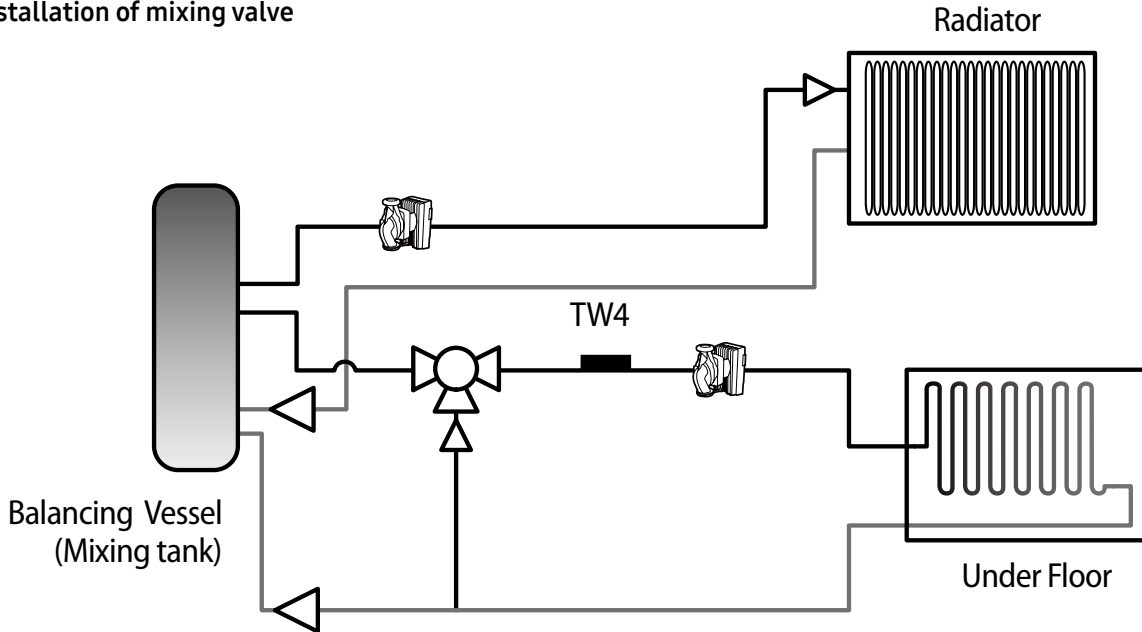

When two different zones are used with different temperature, adjust the temperature of discharge water to high temperature water and control the amount of bypass to provide low temperature water by applying the mixing valve and temperature sensor of the mixing valve (TW4).

- 1 Select a mixing valve from the manufacturers as below (recommended) and install it at the entrance of the zone.
- 2 Install the supplied temperature sensor (TW4) on the rear part of the mixing valve. Install TW4 Sensor within 1m of Mixing Valve.
- 3 Since running time varies depending on the manufacturer, set the FSV (default 90 sec.) by referring to the FSV value below.

Maker		BELIMO	SIEMENS	HONEYWELL
Model code	3 Way Valve	R3020-6P3-S2	VXP45 .20-4 (kvs 4)	V5011E1213
	Actuator	LR230A(-S)	SSB31	ML6420A3015
Running time		90 sec.	150 sec.	60 sec.
FSV(#4046) setting		9	15	6

* The table above is for your reference. It can be changed without advanced notice.

- 4 Set the FSV value by referring to the table below depending on installation environment.

Function	Details	Code	Unit	Default	Min.	Max.
Mixing valve	Use or not	4041	-	0(No)	0	2
	Target temperature difference (Heating) (TW3-TW4)	4042	°C	10	5	15
	Target temperature difference (Cooling) (TW4-TW3)	4043	°C	10	5	15
	Control factor	4044	-		1	5
	Interval of valve control	4045	Min .		1	30
	Running time (10 second unit)	4046	(x10) sec		6	24

* 4041 =1 : Controlled based on the temperature difference (4042, 4043)

* 4041 =2 : Controlled based on the temperature difference of the WL value

5. Installation

Tank integrated hydro unit

ex) Heating

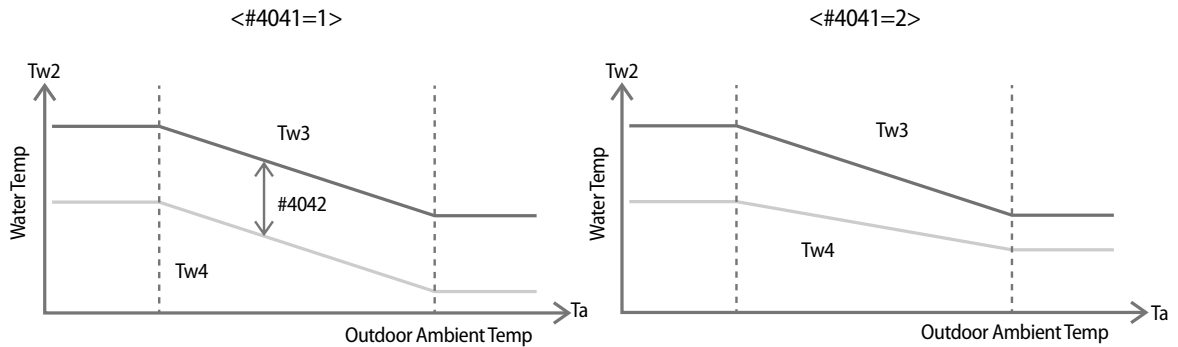

- * The mixing valve is controlled based on the FCU WL value.
- * As the #4044 value increases and the #4045 value decreases, the control speed increases. (Temperature hunting may occur if the control speed increases depending on the load.)
- * The additional pump and mixing valve should be purchased separately. TW4 sensor is included in the product accessories.
- * TW3 : Water temp. sensor 3



- When the thermostat control is set as 'Use', the mixing valve can be used for Zone 1 and Zone 2. (When both FSV #2091 and #2092 are set as 1/2)
- When using Zone control (FSV 4061 = 1), ignore Thermostat signal.

2-zone control using Thermostat

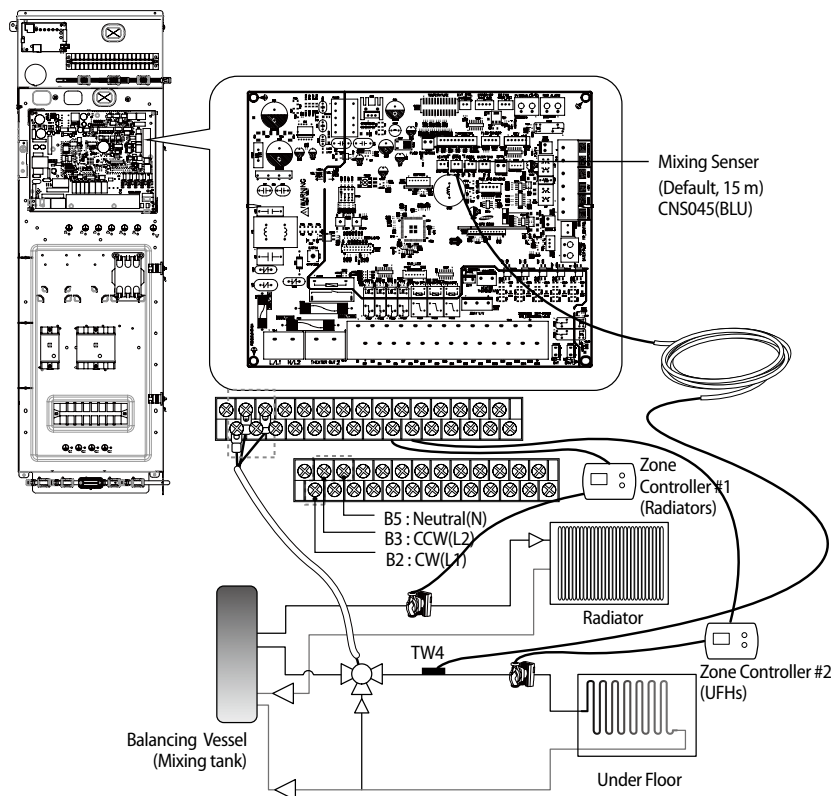

Description	No. of wires	Max. current	Thickness	Supply Scope
Mixing valve	4	22 mA	> 0.75 mm ² , H05RN-F or H07RH-F	Field supply (230 V~, Input)

5. Installation

Tank integrated hydro unit

- 1 Before the installation, hydro unit should be turned off.
- 2 Using the appropriate equipment to correct position of terminal block as shown on the diagram.

2-Zone Control Using Remote Controller

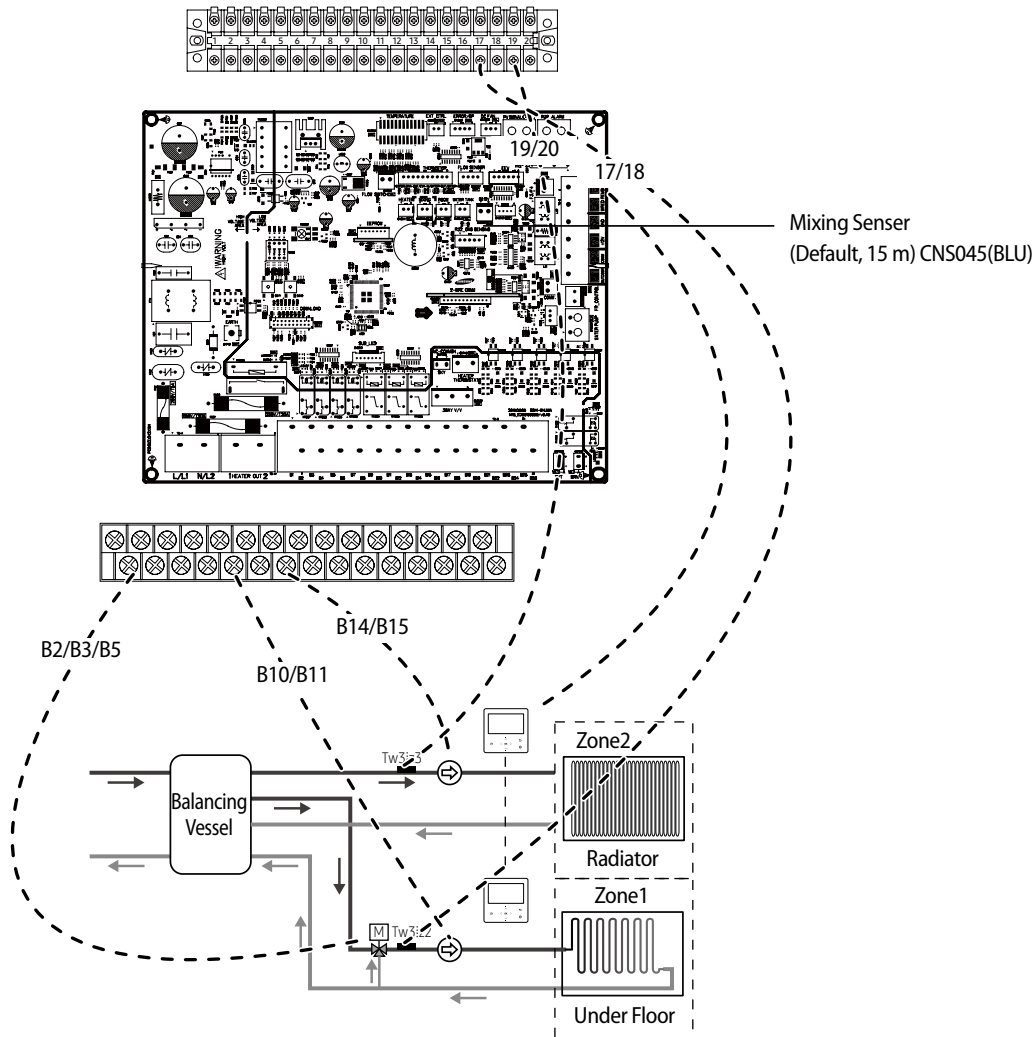

You can operate the 2-zone control using a mixing value, water-out temperature sensors, and built-in or external room temperature sensors installed in a wired remote controller.

When both zones are simultaneously Thermo on, the operation is performed based on Zone2. Therefore, set the zone that you want to have the higher set temperature to Zone2.

(The mixing valve must be installed in the zone that you want to have the lower set temperature.)

- 1 Install the mixing valve. (See "Installation of mixing valve.")
- 2 Install the water-out temperature sensors (Tw2_z1, Tw2_z2) for all zones.
- 3 Unlike the zone control with a thermostat, connect the water pump signal lines to the product.
 - ▶ Zone1 water pump connection: B10 (L1) + B11 (N)
 - ▶ Zone2 water pump connection: B14 (L1) + B15 (N)
- 4 FSV 4061 = 1: Enable the 2-zone control using the wired remote controller.

* If you want to operate the 2-zone control by using water-out temperatures, you have only to complete steps 1 to 4 above.

* If you want to operate the 2-zone control by using room temperatures and built-in temperature sensors in wired remote controllers, you must install two wired remote controllers in each room.

(If you use external room temperature sensors, you can control each room temperature with only one wired remote controller.)

5. Installation

Outdoor unit

Safety Zone

⚠ WARNING

- In case of a leakage the refrigerant must not be able to enter the indoor under any circumstances. The Safety Zone shall not have any building openings such as: Windows, Doors, Light wells, Flat roof windows, Air Inlet / Outlet of ventilation systems, etc.
- R-290 refrigerant is heavier than air and can be collected on the ground. There should be no sinking or deepening of the ground in the safety zone.
- The safety zone should not extend to intact buildings or public spaces.
- The safety zone cannot be modified later to violate the protection rules.

(Unit : mm)

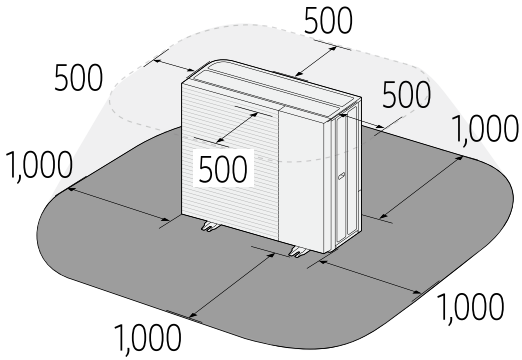
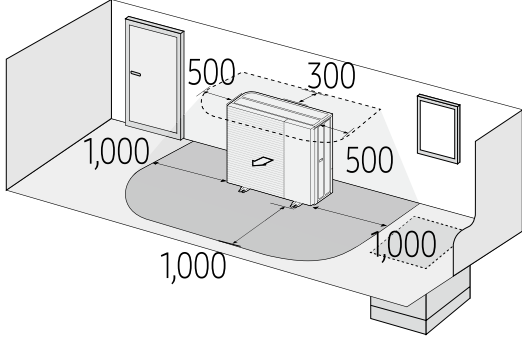
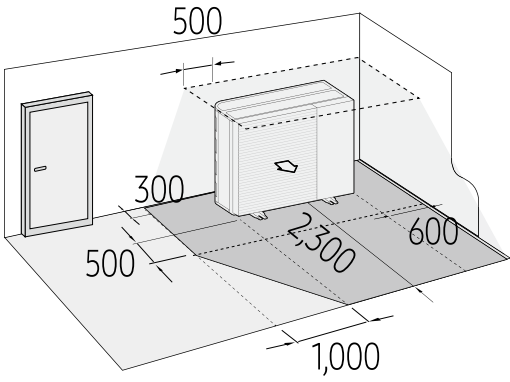
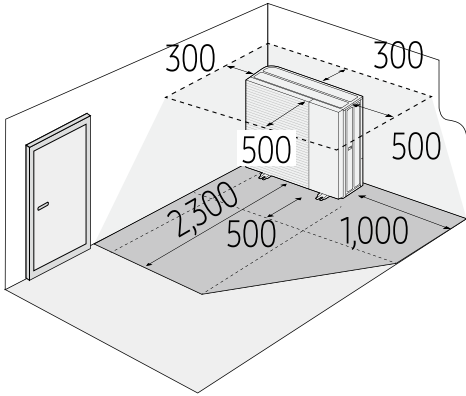
 <ul style="list-style-type: none">• When installed on the ground• When installed in a place with a flat roof	 <ul style="list-style-type: none">• When installed on the ground in front of a building wall
 <ul style="list-style-type: none">• When installed at the right corner of a building	 <ul style="list-style-type: none">• When installed at the Left corner of a building

5. Installation

Outdoor unit

When installing 1 outdoor unit

(Unit : mm)

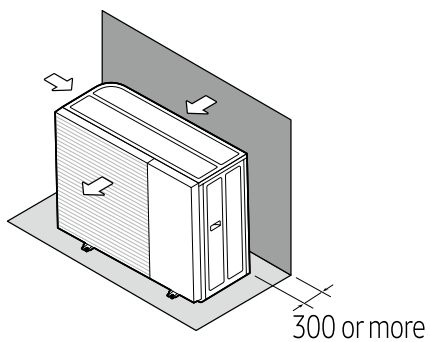

- Wall on suction-side

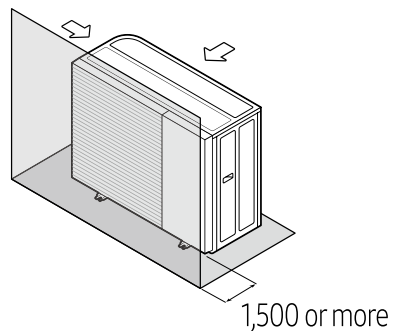

- When the air outlet is towards the wall

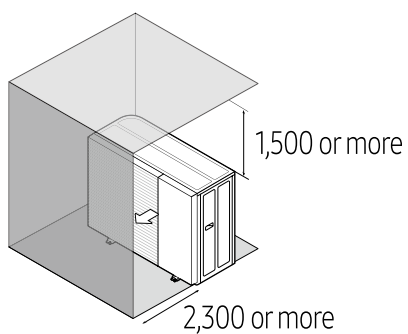

- Top-side obstacle
- Discharge-side obstacle
- Wall on discharge-side

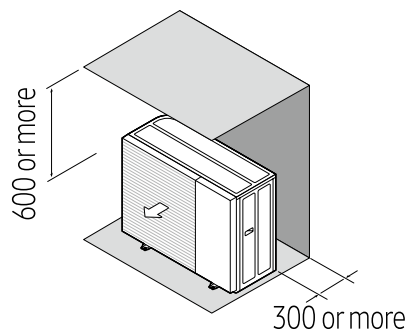

- Top-side obstacle
- Wall on suction-side

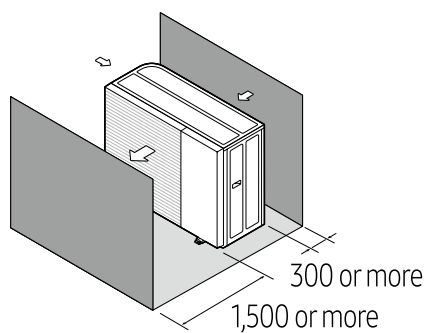

- Suction-side obstacle
- Wall on discharge-side

5. Installation

Outdoor unit

When installing more than 1 outdoor unit

(Unit : mm)

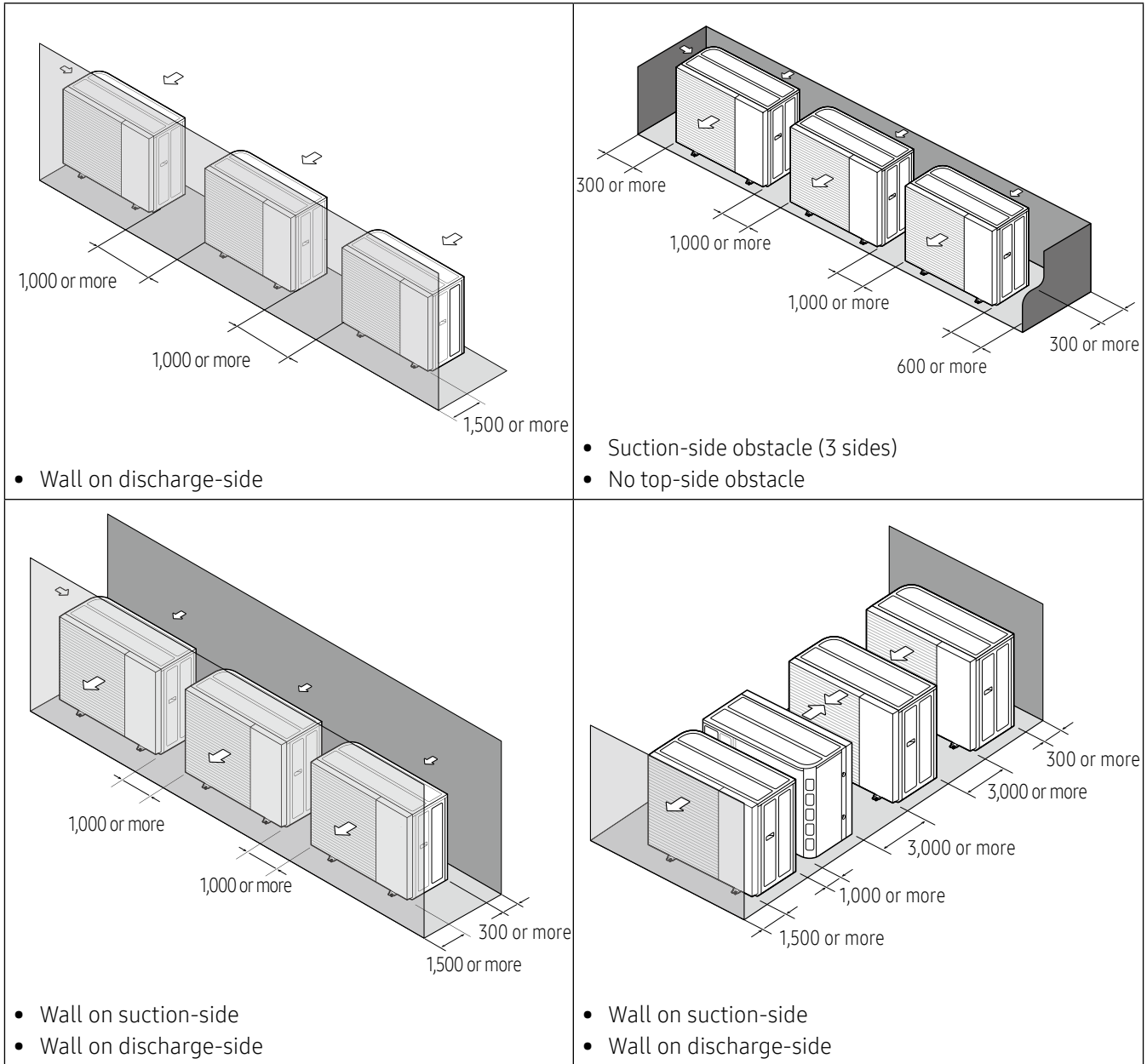

CAUTION

- The units must be installed according to distances declared, in order to permit accessibility from each side, to guarantee correct operation of maintenance or repairing of the products. The unit's parts must be accessible and serviceable under safe working conditions (for people or things).

5. Installation

Outdoor unit

Mounting the outdoor unit

The outdoor unit must be installed on a rigid and stable base to avoid any increase in the noise level and vibration, particularly if the outdoor unit is to be installed in a location exposed to strong winds or at a height, the unit must be fixed to an appropriate support (wall or ground).

CAUTION

- When tightening the anchor bolt, tighten the rubber washer to prevent the outdoor unit bolt connection part from corroding.
- Make a drain outlet around the base for outdoor unit drainage.
- If the outdoor unit is installed on the roof, you have to check the ceiling strength and waterproof the unit.
- The anchor bolt must be 20 mm or higher from the base surface.
- ※ In order to prevent freezing of water drains, additional protection such as application of a heating cable may be required.

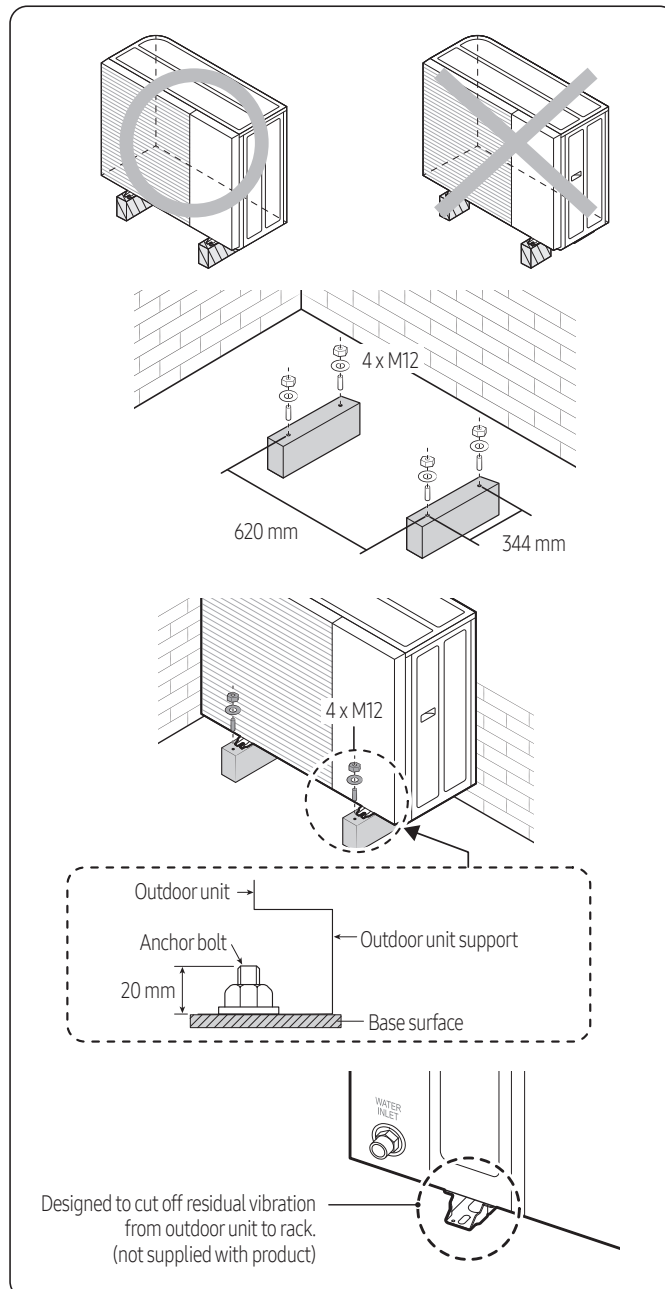

5. Installation

Outdoor unit

General area

While the air to water heat pump is operating in heating mode, ice can accumulate on the surface of the condenser. To prevent ice from growing, the system occasionally enters a defrost mode and the ice on the surface thaws off. Water dripping from the condenser is guided through the drain holes to prevent ice formation inside the base plate at subzero temperatures.

- In case there is not enough space for natural drainage from the outdoor unit, additional drain work is required. Follow the description as per below:
 - Provide a minimum of 150 mm of free space to the floor.
 - Insert the drain plug into the hole at the bottom of the outdoor unit.
 - Connect the drain hose to the drain plug.
 - Make sure dirt and debris cannot block the drain (hose). Clean the base plate whenever needed.
 - For the remaining holes (that do not have the drain plug), insert the drain cap
 - Make sure that the water dripping from the drain hose runs away correctly and safely.

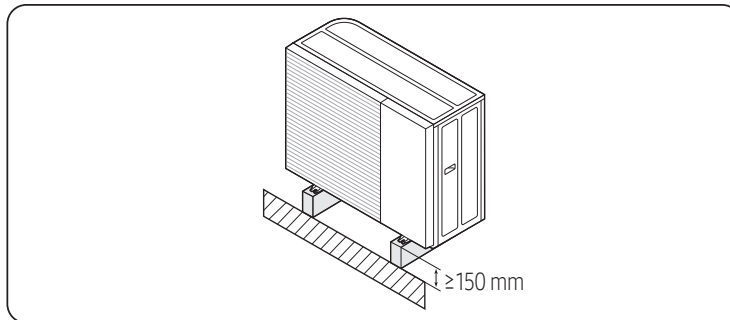

WARNING

- If the drainage is not adequate, it can lead to stagnant water and ice build-up, causing system performance issues and possible damages.

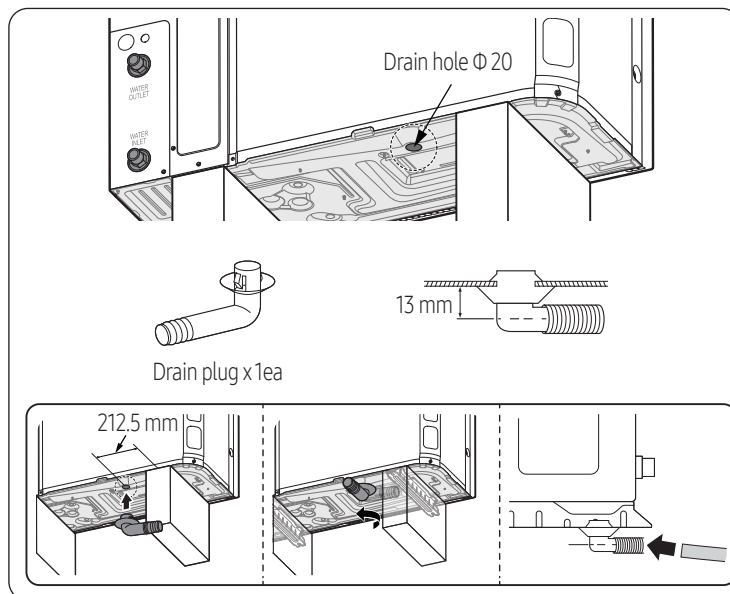

- 1 Prepare a water drainage channel around the foundation, to drain waste water from around the unit.
- 2 If the water drainage from the unit is inadequate, please raise the unit on construction concrete blocks, etc. (the height of the construction should be at least 150 mm).

5. Installation

Outdoor unit

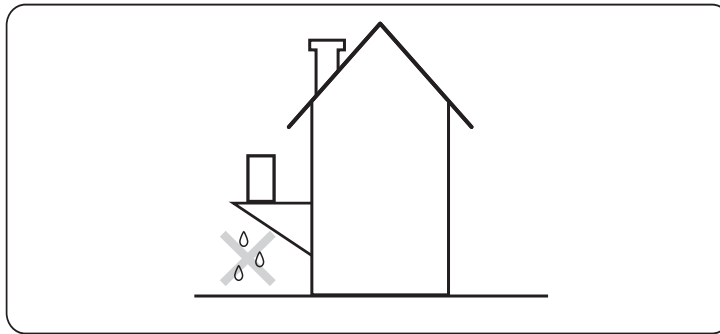

- 3 If you install the unit on a frame, please install a slanted waterproof plate within 150 mm of the underside of the unit to prevent water from splashing against the bottom plate from below.
 - 4 When installing the unit in a place frequently exposed to snow, pay special attention to elevating the foundation as high as the average snow height plus the additional required 150 mm.
 - 5 If you install the unit on a wall support bracket, please install drainage pipework. In order to avoid the drain water from dripping on the floor potentially creating a slippery surface or an ice layer under freezing conditions.
- ※ Please securely mount the outdoor unit before connecting the water piping.

5. Installation

Outdoor unit

About the piping work

Water connections must be made in accordance with the Water Piping and Wiring diagram delivered with the unit, respecting the water inlet and outlet. If air, moisture or dust gets in the water circuit, problems may occur. Therefore, always take into account the following when connecting the water circuit:

- Use clean pipes only.
- Hold the pipe end downwards when removing burrs.
- Cover the pipe end when inserting it through a wall so that no dust and dirt enter.
- Use a good thread sealant for the sealing of the connections.
- The sealing must be able to withstand the pressures and temperatures of the system. When using non-brass metallic piping, make sure to insulate both materials from each other to prevent galvanic corrosion.
- Because brass is a soft material, use appropriate tooling for connecting the water circuit. Inappropriate tooling will cause damage to the pipes.

CAUTION

- Be careful not to deform the unit piping by using excessive force when connecting the piping. Deformation of the piping can cause the unit to malfunction.
- Always use two wrenches (spanners) for tightening or loosening the water connections, and tighten connections with a torque wrench as specified in the below table. If not, connections and parts can be damaged and leak.
- The unit is only to be used in a closed water system. If applications are in open water circuit, it will generate heat exchangers fouling, corrosion, and leak.

Name	Tightening torque	
BSPP1	350~380 kgf•cm	34~37 N•m

Connecting the water pipes

Connecting the water piping typically follows the below procedure:

- 1 Connect the water piping to the outdoor unit.
- 2 Connect the water piping to the indoor unit.
- 3 Connect the recirculation piping.
- 4 Connect the drain hose to the drain.
- 5 Fill the water circuit.
- 6 Fill the DHW tank.
- 7 Insulate the water piping.

NOTE

- Do not use excessive force when connecting the piping. Deformation of the piping can cause malfunctioning of the unit.
 - Connect the shut-off valve (with integrated filter) to the outdoor unit water inlet, using the thread sealant. At this time, the filter should be directed downward so that impurities can be collected.
 - Connect the field piping to the shut-off valve.
 - Connect the shut-off valve to the outdoor unit water outlet, using the thread sealant.
-

5. Installation

Outdoor unit

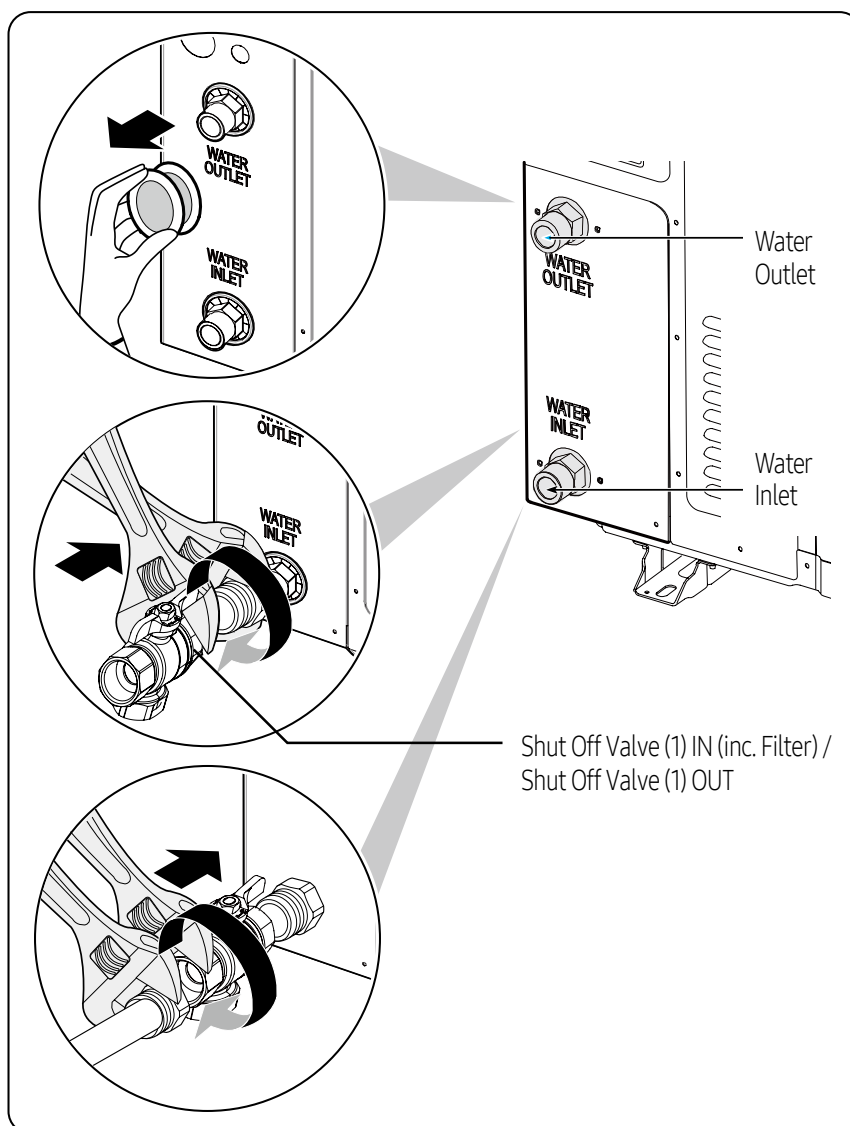

NOTE

- About the shut-off valve with integrated filter:
 - The installation of the shut-off valve at the water inlet is mandatory.
 - Mind the flow direction of the valve.

Water Charging

Fill water into the outdoor unit by opening the shut-off and drain valves.

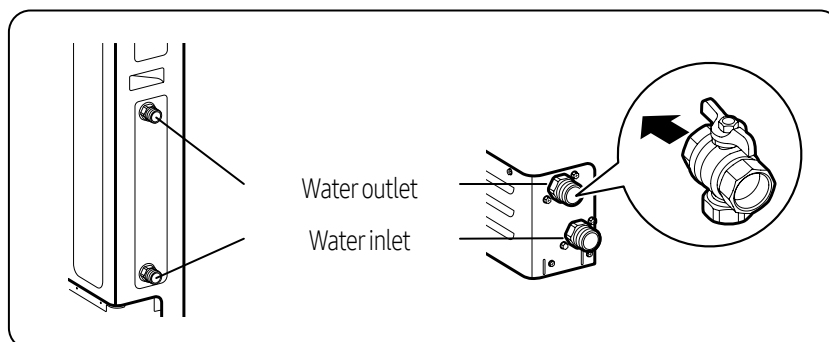

5. Installation

Outdoor unit

⚠ CAUTION

- The operating range of leaving water temperature is 15~75°C at heating conditions and 5~25°C at cooling conditions.
- The minimum required water flow for operation is 7 liters/min. At all times the required water flow-rates should remain. Otherwise, the unit can stop due to a lack of water.
- Water quality must be according to EN directive 98/83 EC. (Please refer to the reference guide for details.)
- Charge the water higher than pressure of 1.0 bar by using make-up water assembly(Field supply).
(The water pressure indicated on the manometer will vary depending on the water temperature) The nominal water pressure in the system should remain about 1.0 bar at all times to avoid air entering the water system.

Setting capacity and pre-pressure of the expansion vessel

When it is required to change the default pre-pressure of the expansion vessel(1 bar), keep in mind the following guidelines:

- ▶ Use only dry nitrogen to set the expansion vessel prepressure.
- ▶ Inappropriate setting of the expansion vessel prepressure will lead to malfunction of the system. Therefore, the pre-pressure should only be adjusted by a licensed installer.

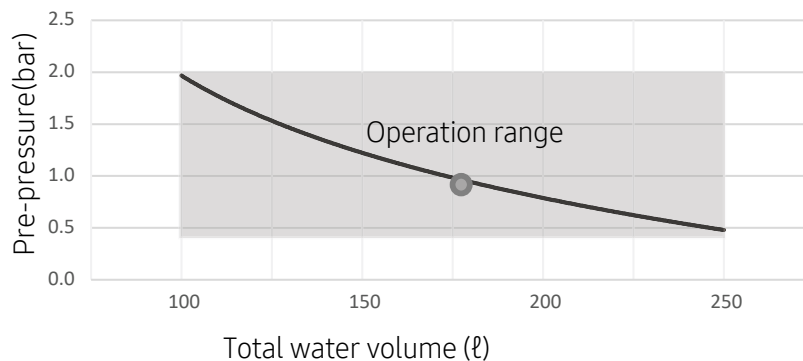

Installation height difference ^(a)	Water volume	
	<185 Litres	>185 Litres
<7m	No pre-pressure adjustment required.	Actions required: <ul style="list-style-type: none"> • Pre-pressure must be decreased, calculate according to “Calculating the pre-pressure of the expansion vessel”. • Check if the water volume is lower than maximum allowed water volume.
>7m	Actions required: <ul style="list-style-type: none"> • Pre-pressure must be increased, calculate the appropriate value following by “Calculating the pre-pressure of the expansion vessel”. • Check if the water volume is lower than maximum allowed water volume. 	Expansion vessel of the unit too small for the installation.

(a) Installation height difference: height difference(m) between the highest point of the water circuit and the indoor unit. If the unit is located at the highest point of the installation, the installation height is considered 0m.

- When Expansion vessel has a capacity 8 liters and 1bar pre-charged. Water volume of total system for reliable performance is minimum 30 Liter (AE050/080CXVD**), 50 Liter (AE120/160CXVD**).

5. Installation

Outdoor unit

Calculating the pre-pressure of the expansion vessel

- The pre-pressure(P_g) to be set depends on the maximum installation height difference(H) and is calculated as below :
- $$P_g = (H/10 + 0.3) \text{ bar}$$

Protection of the water circuit freezing

To prevent the hydraulic components from freezing, it has a freezing protection function that includes activation of the pump at low temperatures.

However, in case of a power failure, these functions cannot guarantee protection.

To protect the water circuit from freezing, any one of the following acts shall be performed.

- Add glycol to water. Glycol lowers the freezing point of water.
- Install the anti-freeze valve. The anti-freeze valve discharges water from the system before it freezes.

Freeze protection by glycol

Freeze protection solutions must use propylene glycol with a toxicity rating of Class 1 as listed in Clinical Toxicology of Commercial Products, 5th Edition.

WARNING

- Ethylene glycol is toxic and must not be used in the primary water circuit in case of any cross-contamination of the portable circuit.
- If you add glycol to the water, do NOT install anti-freeze valve, to avoid Glycol leaking out of the anti-freeze valves into the environment.
- If an anti-freeze protection is used, it will result in increased pressure drop and it may also cause a slight capacity reduction.

CAUTION

- Due to the presence of glycol, corrosion of the system is possible. Uninhibited glycol will turn acidic under the influence of oxygen. The acidic uninhibited glycol attacks metal surfaces and forms galvanic corrosion cells that cause severe damage to the system.
- A glycol with corrosion inhibitors is selected to counteract acids formed by the oxidation of glycols.
- No automotive glycol is used because their corrosion inhibitors have a limited lifetime and contain silicates which can foul or plug the system.
- Galvanized pipes are NOT used in glycol systems since the presence may lead to the precipitation of certain components in the glycol's corrosion inhibitor.

Unit resistance and PHE resistance by glycol concentrate

The unit is composed of water pipes and PHE basically. To ensure correct operation and predict the expected performance, Flow and Resistance table can be used and Flow and resistance characteristic is dependent on Glycol concentration.

5. Installation

Outdoor unit

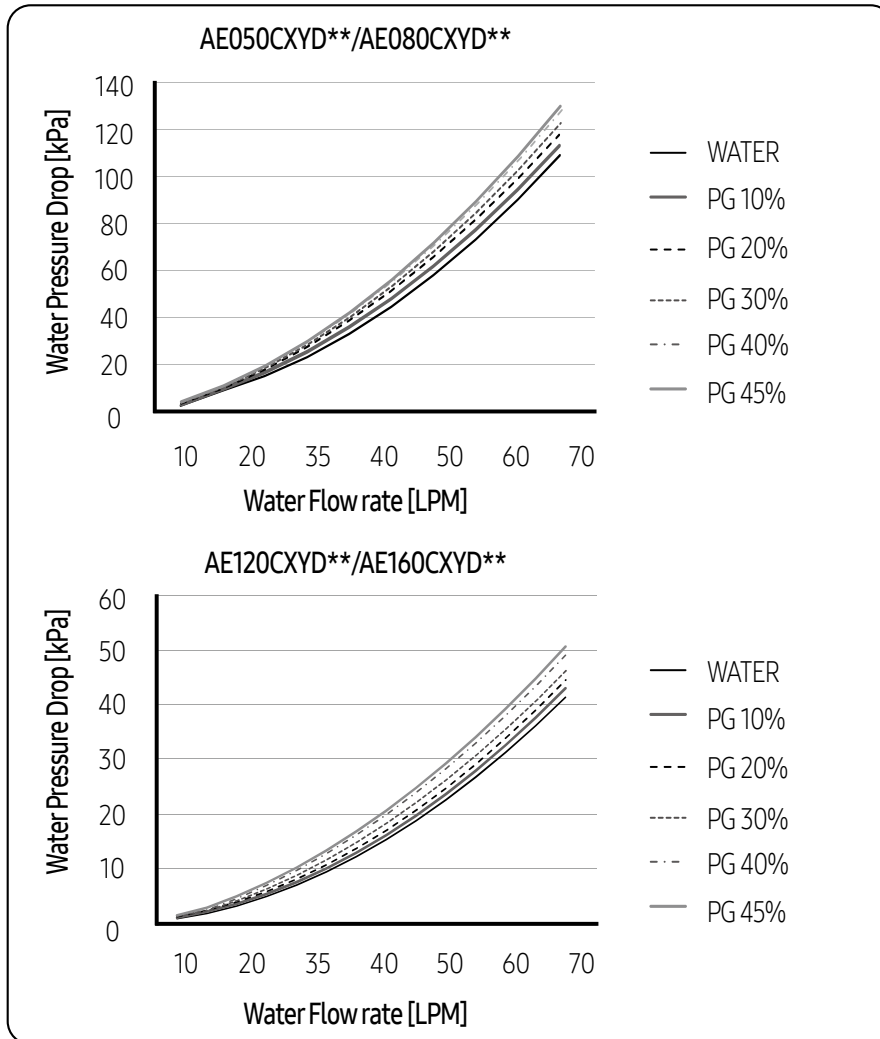

Changing Glycol concentration can cause the pressure drop of the system and it can lead to make flow rate slow. Just in case of performance degradation, installer shall be careful of flow rate changes.

The required concentration of glycol depends on the lowest expected outdoor temperature, and on whether you want to protect the system from bursting or from freezing. To prevent the system from freezing, more glycol is required. Add glycol according to the table below.

Freezing Points of Propylene Glycol - Water Mixtures		
Percent Propylene Glycol [wt.%]	Freezing Point [°F]	Freezing Point [°C]
0	32	0
10	26	-3
20	20	-7
30	10	-12
36	0	-18
40	-5	-20
43	-10	-23
48	-20	-29

5. Installation

Outdoor unit

Outdoor water piping insulation

The complete water circuit, inclusive all the piping, must be insulated to prevent condensation during cooling operation and reduction of the heating and cooling capacity as well as prevention of freezing of the outside water piping during winter time. The thickness of the sealing materials must be at least 9 mm with $\lambda=0.035$ W/mK in order to prevent freezing on the outside water piping. If the temperature is higher than 30°C and the humidity is higher than RH 80%, then the thickness of the sealing materials should be at least 20 mm in order to avoid condensation on the surface of the sealing.

For piping in free air, it is recommended to use the insulation thickness as shown in the below table as a minimum (with $\lambda=0.035$ W/mK).

Piping length (m)	Minimum insulation thickness (mm)
< 20	19
20 ~ 30	32
30 ~ 40	40
40 ~ 50	50

NOTE

- This recommendation ensures good operation of the unit, however, local regulations may differ and shall be followed.

Minimum active water volume

The minimum active water volume of the system is the amount of water which is always pumped around, even when all valves in the system are closed. The use of a buffer tank can increase the active volume and therefore the operation time between compressor start and stop.

Ideally, systems should be designed for around 12 to 15 minutes of operation, in order to meet with our declared efficiencies. This time frame is based on a maximum of 4 On/Off cycles per hour. The required minimum active water volume can be calculated via the below stated formula:

$$V_{\min} = \frac{t_{\min} \times \Phi_{\min}}{C_{\text{water}} \times \Delta T}$$

V_{\min} : Minimum active volume

t_{\min} : Minimum allowed operation time is 12 min or 720 sec per cycle

Φ_{\min} : Minimum compressor output

C_{water} : Specific heat of water (4,2)

ΔT : Temperature increase (5-10 K)

[dm³]

[s, sec]

[kW = kJ/s]

[kJ/kg*K]

[K]

5. Installation

Outdoor unit

Electrical wiring diagram

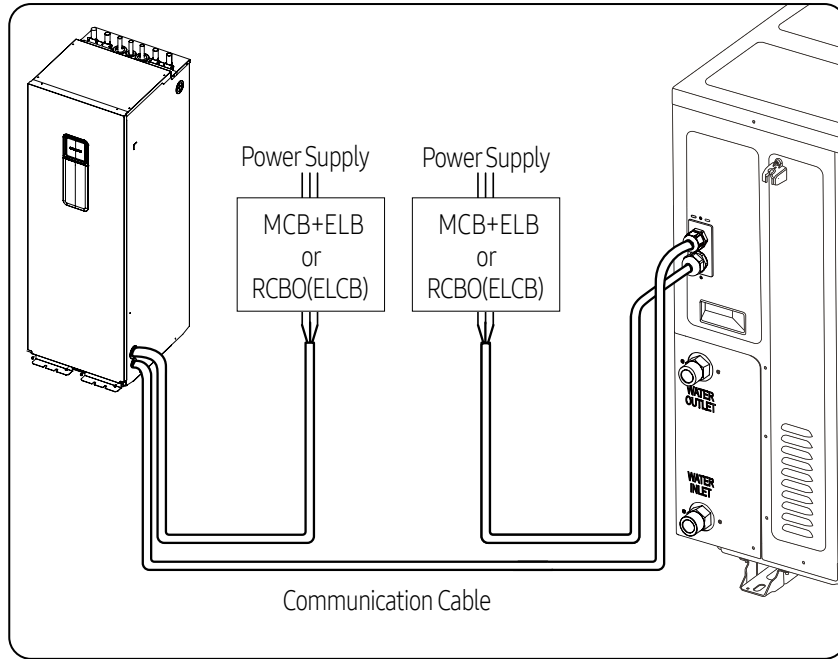

Specification of power cable

- 1 Phase
 - The power cables are not supplied with the air to water heat pump.
 - Power supply cords of parts of appliances for outdoor use shall not be thinner than polychloroprene sheathed flexible cord (Code designation IEC:60245 IEC 57 / CENELEC:H05RN-F)
 - This equipment complies with IEC 61000-3-12.

Outdoor unit	Rated		Voltage Range		MCA	MFA
	Hz	Volts	Min	Max	Min Circuit Amps.	Max Fuse Amps.
AE050CXYDEK	50	220-240	198	264	16.1	17.6
AE080CXYDEK	50	220-240	198	264	26	28.6
AE120CXYDEK	50	220-240	198	264	32	35.2
AE160CXYDEK	50	220-240	198	264	32	35.2

- 3 Phase
 - The power cables are not supplied with the air to water heat pump.
 - Power supply cords of parts of appliances for outdoor use shall not be lighter than polychloroprene sheathed flexible cord (Code designation IEC:60245 IEC 66 / CENELEC:H07RN-F)
 - This equipment complies with IEC 61000-3-12 provided that the short-circuit power (SSC) is greater than or equal to 3.3[MVA] at the interface point between the user's supply and the public system. It is the responsibility of the installer to ensure, by consultation with the energy company if necessary, that the equipment is connected only to a supply with a short-circuit power (SSC) greater than or equal to 3.3[MVA].

Outdoor unit	Rated		Voltage Range		MCA	MFA
	Hz	Volts	Min	Max	Min Circuit Amps.	Max Fuse Amps.
AE080CXYDGK	50	380-415	342	457	16.1	17.7
AE120CXYDGK	50	380-415	342	457	16.1	17.7
AE160CXYDGK	50	380-415	342	457	16.1	17.7

5. Installation

Outdoor unit

Terminal block specification

- 1 Phase

(Unit: mm)

AC power: M5 screw

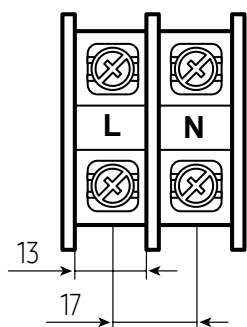

Communication: M4 screw

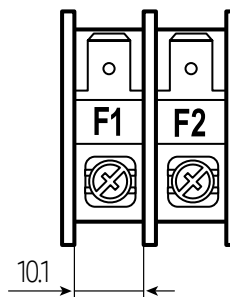

- 3 Phase

(Unit: mm)

AC power: M5 screw

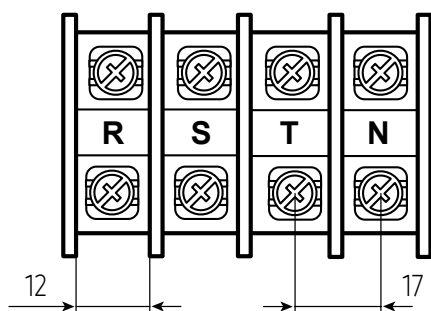

Communication: M4 screw

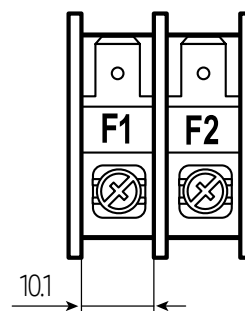

Outdoor wiring

- 1 Open the switch side cover.

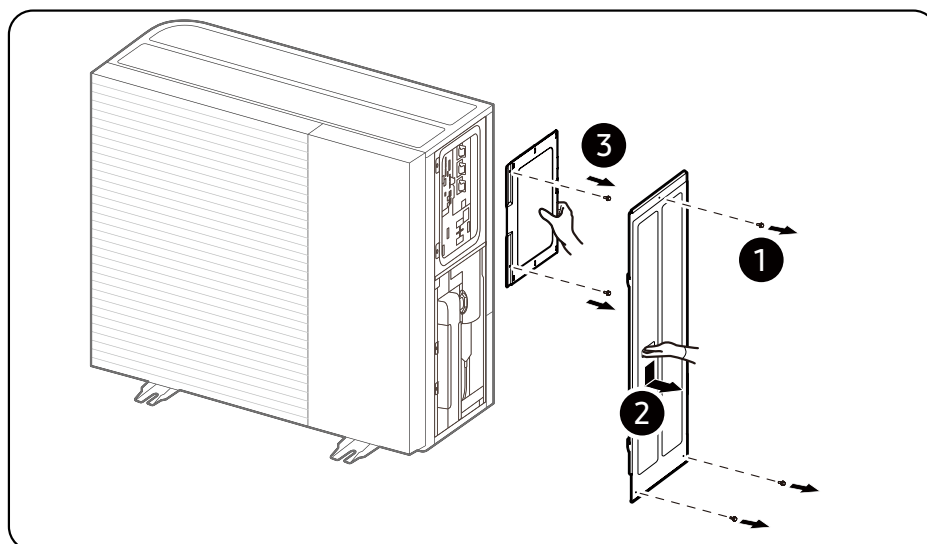

5. Installation

Outdoor unit

- 2 Insert the cables at the rear of the unit, and route them through the factory mounted cable sleeves into the switch box.

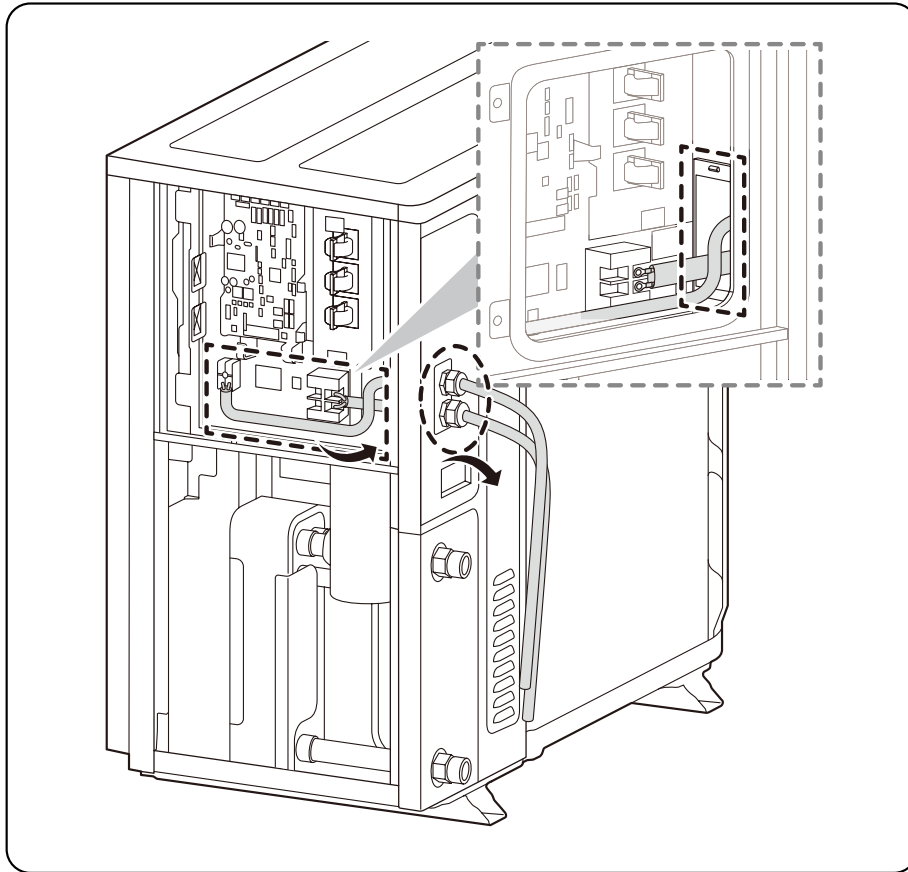

Power and communication cable configuration

- Power supply cable must be guided through the knock-out hole on the bottom-right or right side of the cabinet.
- Guide the communication cable through the designated knockout hole on the bottom-right side of the front part.
- Install the power and communication cable using a separate cable protection tubing.
- Fix the conduit to the knock-out hole on the outdoor unit by using a conduit bushing and nut.

To connect the power supply

- Two cables must be connected to the outdoor unit
 - The communication cable between the indoor and outdoor unit.
 - The power cable between the outdoor unit and the auxiliary breaker.
- Especially for the Russian and European market, before installation, the supply authority should be consulted to determine the supply system impedance to ensure compliance.

CAUTION

- You should connect the power cable into the power cable terminal and fasten it with a clamp.
 - The unbalanced power must be maintained within 2% of the supply rating.
 - If the power is unbalanced greatly, it may shorten the life of the electrical components. If the unbalanced power is exceeding 4% of the supply rating, the control kit is protected, stopped and an error code is displayed.
 - To protect the product from water and possible shock, keep the power cable and the connection cord of the control kit and outdoor units within ducts (with appropriate IP rating and material selection for your application).
 - Ensure that the main supply connection is made through a disconnection switch within your arm's reach, that disconnects all poles, with contact gap of a least 3 mm.
-

5. Installation

Outdoor unit

Route the cable through the frame

- Connect the wires to the terminal block and fix the cable with the cable tie.

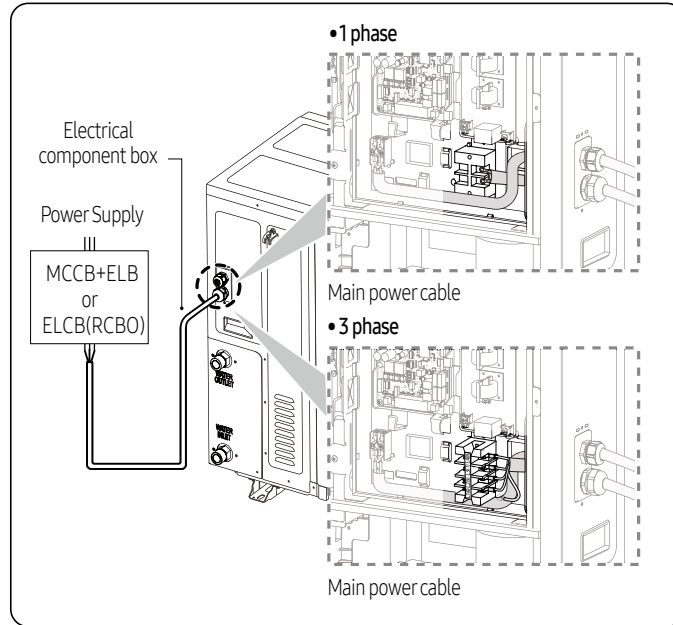

- When installing electrical wiring: tension on the cable(s) must be avoided.
- Earth wire for the indoor unit and outdoor unit cables must be clamped to a suitable ring terminal clamp (not supplied)
- For the power cable, use the grade H07RN-F or H05RN-F materials.
- Power supply cords of parts of appliances for outdoor unit use shall not be thinner than polychloroprene sheathed flexible cord. (Code designation IEC:60245 IEC 57 / CENELEC: H05RN-F or IEC:60245 IEC 66 / CENELEC: H07RN-F)

To connect the communication cable

- The communication cable between the indoor and outdoor unit.
- Route the cable through the frame.
- Connect the wires to the terminal block and the earth screw (single side, the other end of the protective shield is not again connected to earth).
- Fix the cable with a cable tie.

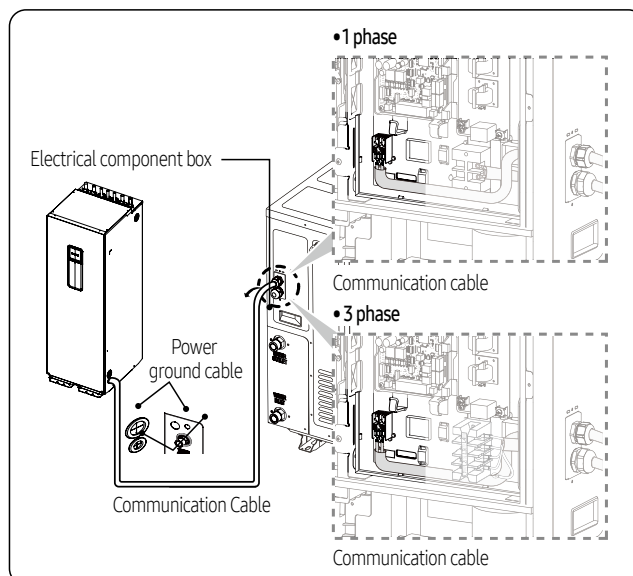

5. Installation

Outdoor unit

- Specification of communication cable

Communication cable	Specifications
0.75 mm ² , 2 wires shielded	LiYCY

Important information: regulation regarding the refrigerant used

Please fill in the following with indelible ink on the refrigerant charge label supplied with this product and on this manual.

- ① the factory refrigerant charge of the product.
- ② the additional refrigerant amount charged in the field.

Unit	kg	tCO ₂ e
①, a		
②, b	DO NOT CHARGE	

Refrigerant type	GWP value
R-290	3

- GWP: Global Warming Potential
- Calculating tCO₂e: kg x GWP/1000

NOTE

- a Factory refrigerant charge of the product: see unit name plate.
- b Additional refrigerant amount charged in the field.
(Refer to the above information for the quantity of refrigerant replenishment.)

CAUTION

- The filled-out label must be adhered in the proximity of the product charging port.
(ex. onto the inside of the stop valve cover.)

5. Installation

Control Kit

Mono outdoor + Control kit

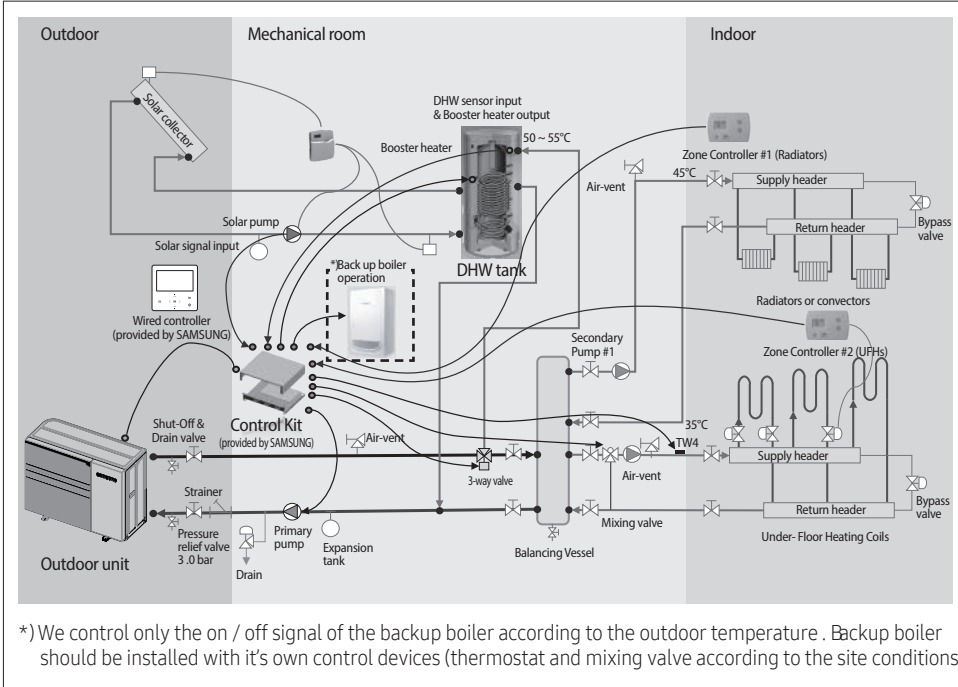

• Samsung is not responsible for performance and stability of the backup boiler.

Power and communication with outdoor unit

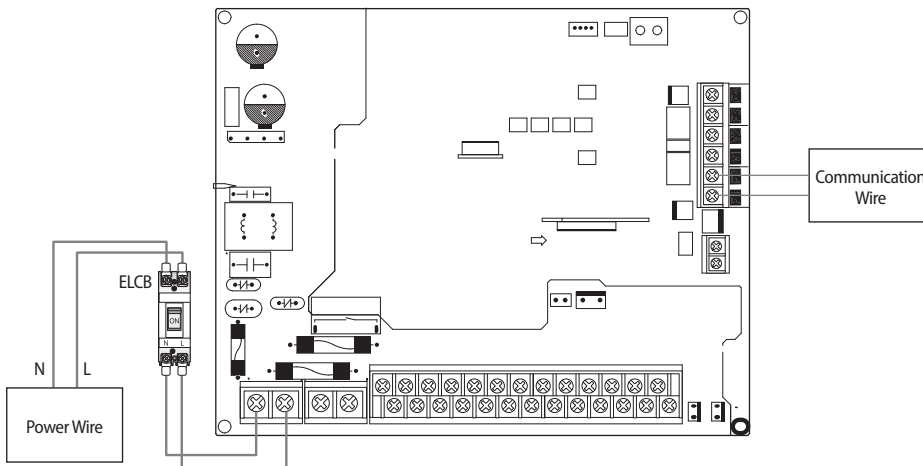

• Be careful when connecting L, N.

5. Installation

Control Kit

Connecting the power wire

1. Connect 'Live' and 'Neutral' power line with 'L, N' of a ELCB.
2. Connect 'L,N' of a ELCB with 'A1 and A2' in TB-A.
3. Connect 'Protective Earth' line with 'Earth screw' In case.

Recommended wire specification

Load	Power Supply	Power Cable	Max. Length
		mm ² , wires	m
Do NOT use Heater (Water Pump, Valve, Wired RMC)	1Ø, 220-240V, 50Hz	1.5 / 3	L < 10m
		2.5 / 3	10m < L
4.0 / 3		L < 10m	
6.0 / 3		10m < L	

- ▶ The power cable is not supplied with Air to water heat pump.
- ▶ This equipment with "IEC 61000-3-12".
- ▶ Power supply cords of parts of appliances for outdoor use shall not be lighter than polychloroprene sheathed flexible cord. (Code designation IEC:60245 IEC 57 / CENELEC: H05RN-F or IEC:60245 IEC 66 / CENELEC: H07RN-F)
- ▶ When installing the control kit in a computer room or net work room, server room or in the presence of risk of disturbance to the communication cable, use the double shielded (tape aluminium / polyester braid + copper) cable of FROHH2R type.

Connecting the communication wire

- ▶ Connect outdoor unit's F1&F2' with control kit's F1&F2 in TB-C' by 2 core cable.

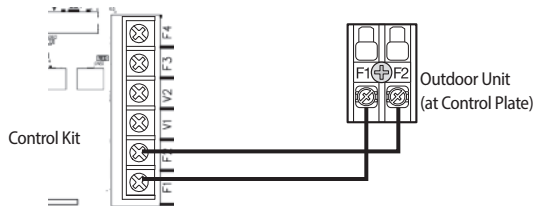

Communication with a wired remote controller (1 unit)

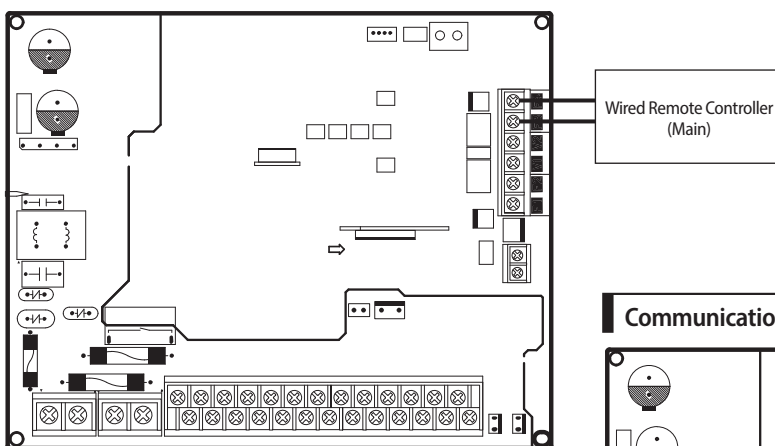

Communication with a wired remote controller (2 units)

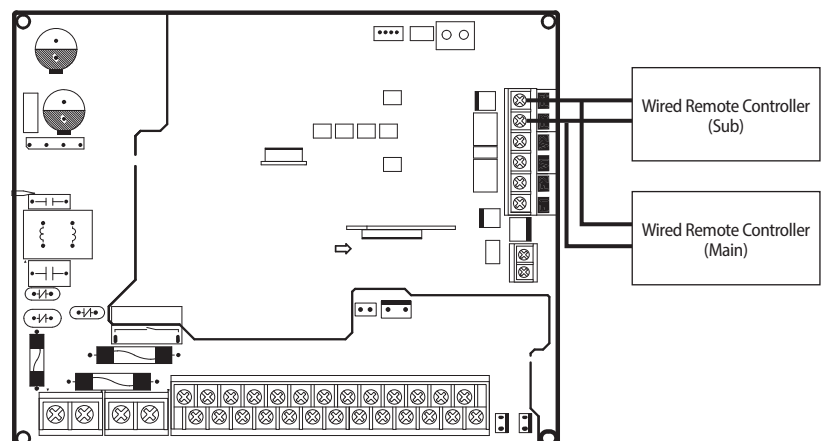

5. Installation

Control Kit

Temp. Sensor for DHW, Backup heater and a Water Flow Sensor

External wiring to control a switch of relay by an installer

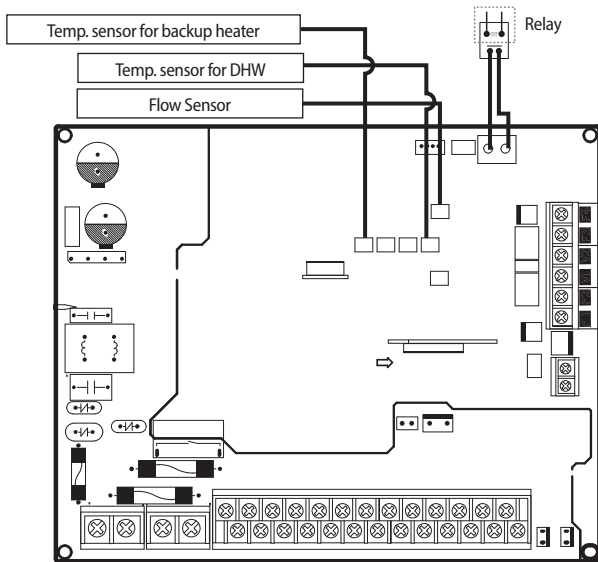

Connecting a temp. sensor wire into DHW

1. Put the sensor side of a temp. sensor wire into the designated location in a DHW.
2. Connect the other side of the line at CNS042.

Connecting a temp. sensor wire to outlet of backup heater

1. Put the sensor side of a temp. sensor wire into the designated location in a backup heater.
2. Connect the other side of the line at CNS047.

Connecting a flow sensor

1. Install a flow sensor in water line.
2. Connect a wire a flow sensor into 'CNS057' connector.

Connecting a PV(Photovoltaic) Signal / Peak power control Signal

1. Install as above diagram.
2. Connect the PV / Peak power control signal wire to the 'CNS046' connector.



• It operates according to the setting of FSV, and both functions can not be used at the same time.
(PV Control / Peak power control)

Backup heater

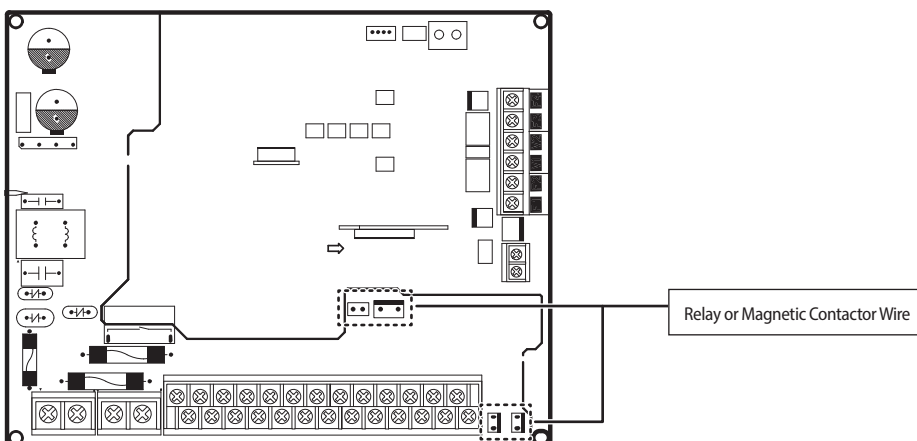

5. Installation

Control Kit

Connecting a relay or a magnetic contactor for a backup heater (Not Directly connect a backup heater)

- Control signals are provided only when CNP401 (Heater Thermostat) is connected.
- Connect a "relay or a magnetic contactor" with "CNP003,CNP001,CNP002".
 - ▶ When a backup heater mode is "ON" at 1st step, a control signal of AC 230V goes through CNP003 and CNP001.
 - ▶ When a backup heater mode is "ON" at 2nd step, a control signal of AC 230V goes through CNP003 and CNP002.

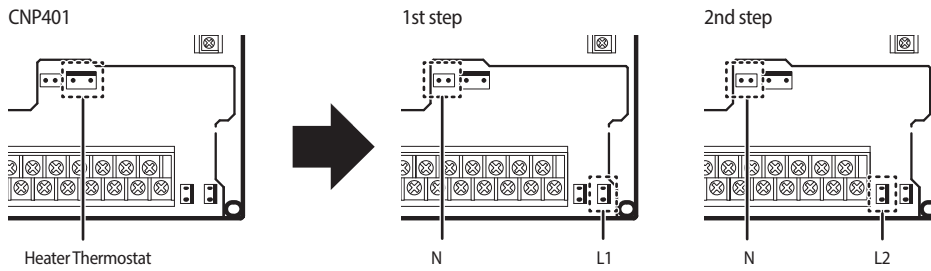

NOTE This port can NOT supply enough power for driving a backup heater. It's just for providing a ON/OFF control signal. Maximum current is 0.5A.

Specification table

Part	Specification
Tab-Terminal (output)	Step1 : CNP003, CNP001 Step2 : CNP003, CNP002
Connection load	Relay or Magnetic contactor for a control signal
Output(CNP003,CNP001 or (CNP003,CNP001)+(CNP003,CNP002)	AC 230V (MAX 0.5A)

Backup boiler

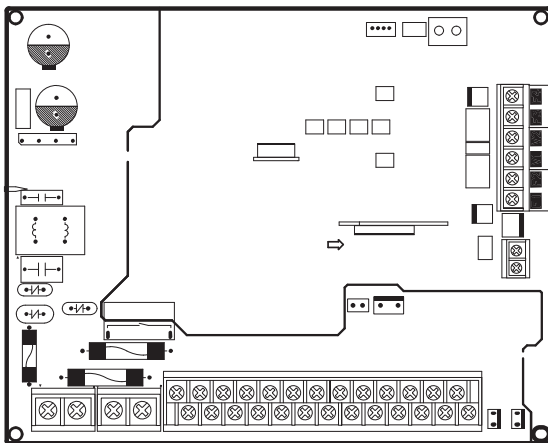

Connection of the back-up boiler

Description	No. of wires	Min. / Max. current	Thickness	Supply Scope
Back-up Boiler	2+ground	10mA / 50mA	0.75mm ² H05RN-F or H07RN-F	Field supply (220-240V~, Input)



B5 : Neutral (N)
B4 : Back-up boiler (L)

When it set back up boiler on the control kit (relay off)

When it order to back up boiler operates (relay on)

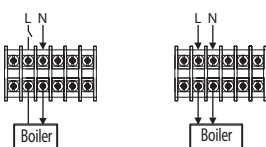

- Before the installation, control kit should be turned off.
 - Using the appropriate equipment to correct position of terminal block as shown on the diagram.
 - Make sure EXT-CTRL signal of back up boiler must be 220-240V~.
 - Do not connect supply power of back up boiler directly.
- * Heat pump does not work when the Back-up boiler operates.

5. Installation

Control Kit

Connection guide of additional pump

Case 1) INV. pump

Connect the PWM control external type pump to PWM terminal block and power cable to the external contact terminal. The maximum number of additional pump installation is one inverter pumps (Input power 100W).

1. Power supply (For additional INV. Pump)
2. PWM control (For additional INV. Pump only)

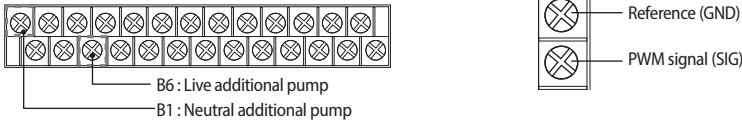

CAUTION • If there is wrong wiring between PWM and reference, INV. Water Pump may not work or wrong operation.

PWM characteristic curve

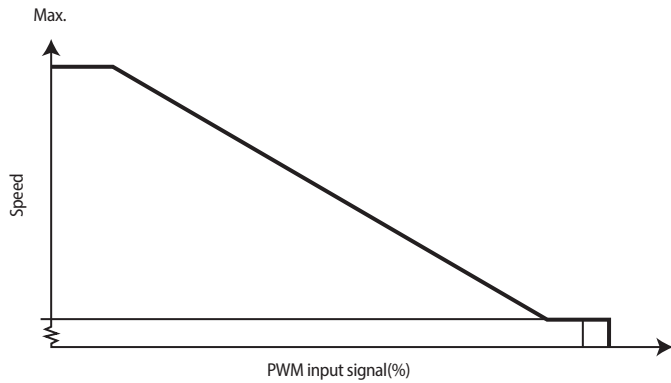

The additional pump should be the same type of product as the above graph.
5~16kW : GRUNDFOS UPMM 25-95 (Heating Type)

Case 2) AC pump

The maximum number of additional pump installation is one AC pumps (Input power 100W).

1. Power supply (AC Pump)

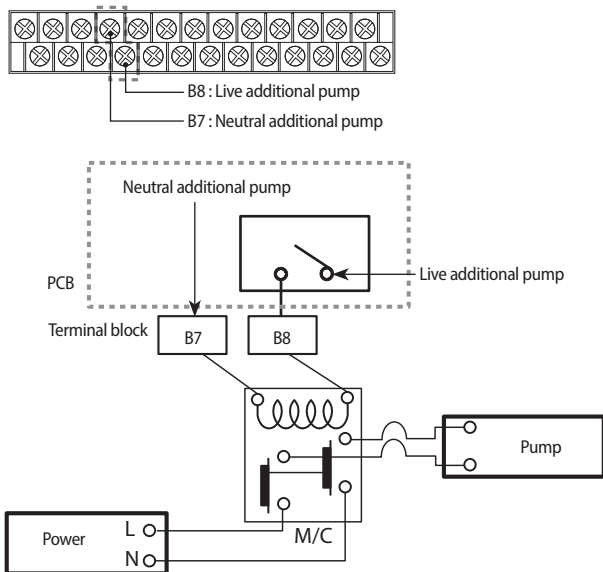

CAUTION • Terminal of this product is for additional water pump and the maximum allowable current is 0.5 A.

5. Installation

Control Kit

Connection of the 2-way valve

Description	No. of wires	Min. / Max. current	Thickness	Supply Scope
Motorized 2-way valve to shut off UFH loops during cooling.	2+ground	10mA / 50mA	> 0.75 mm ² , H05RN-F or H07RH-F	Field supply (220-240V~, Output)

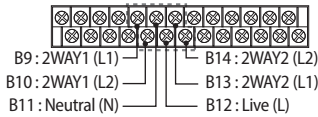

* Connection of 2 wires 2-way valve

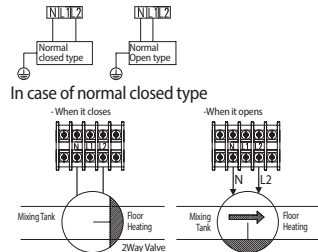

In case of normal open type

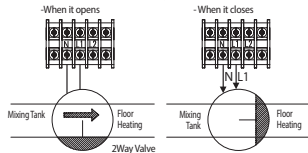

2-way motorized valve

- ▶ When outlet water temperature reach to lower than 16 °C in cooling mode, UFH loops will be closed.
 - ▶ 220-240V~
 - ▶ 2 wires(Normal Open or Normal Close)
1. Before the installation, control kit should be turned off.
 2. Using the appropriate equipment to correct position of terminal block as shown on the diagram.
 3. Make sure what type is you use.
 - Normal OPEN or Normal CLOSED.

CAUTION ⚠

- There are 2 types of 2-way valve, normal open type and normal closed type. Make sure to connect terminals to right positions of terminal block. As detailed on the wiring diagram and illustrations above.

Connection of the 3-way valve

Description	No. of wires	Min. / Max. current	Thickness	Supply Scope
Diverting type 3way valve	4	10mA / 50mA	> 0.75 mm ² , H05RN-F or H07RN-F	Field supply (220-240V~, Input)

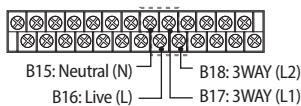

Status	L1	L2
A (Initial)	OFF	ON
B	ON	OFF

3-way diverting valve for water tank

- ▶ Diverting typecooling mode, UFH loops will be closed.
 - ▶ 220-240V~
1. Before the installation, control kit should be turned off.
 2. Using the appropriate equipment to correct position of terminal block as shown on the diagram.
 3. Make sure what type of 3 way V/V you use.

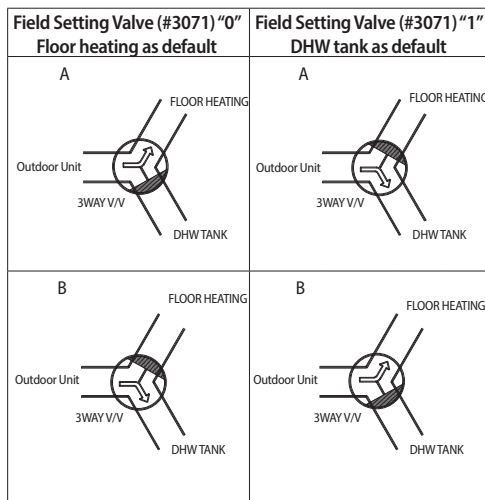

5. Installation

Control Kit

Connection of the thermostat

escription	No. of wires	Max. current	Thickness	Supply Scope
Room Thermostat	4	22mA	> 0.75 mm ² , H05RN-F or H07RH-F	Field supply (220-240V~, Input)

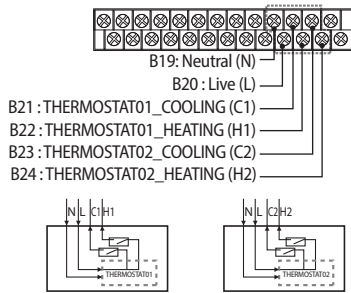

1. Before the installation, control kit should be turned off.
2. Using the appropriate equipment to correct position of terminal block as shown on the diagram.
3. Make sure what type is you use.
 - Contact signal must be "L". When you install two thermostats, thermostat2 is prior to thermostat1.

CAUTION • Product will not operate when signal for cooling and heating mode is inputted at the same time.

Connecting for external contact functions (Only MIM-E03EN model)

Screw size	Tightening torque (N-m)	Part	Terminal code
M3	0.5~0.75	10P Terminal block	1~10

Connecting external sensors for zone control

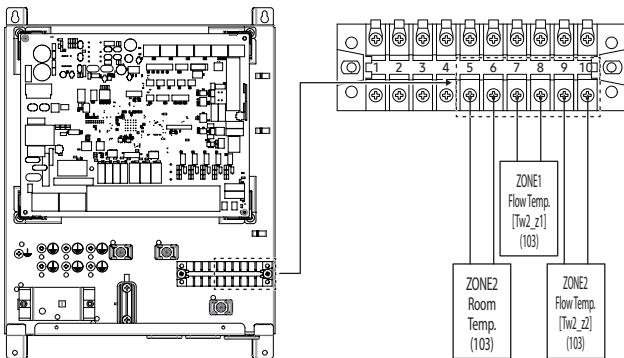

CAUTION • When connecting sensors, use a Thermistor with the specifications of 10 kΩ at 25 °C, B constant = 3435 k.

Connecting for SG Ready(Smart Grid Ready) control

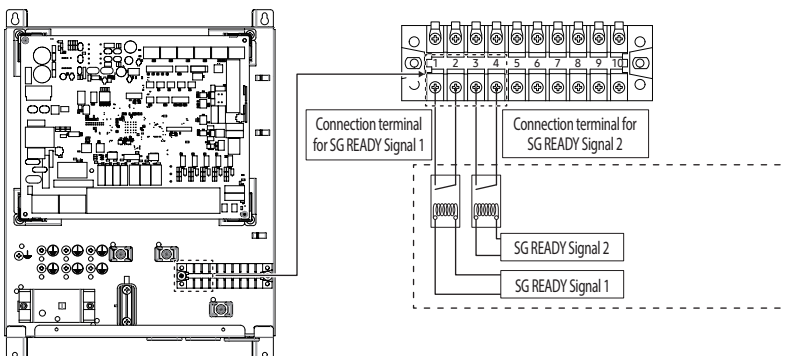

SG READY Signal 1	SG READY Signal 2	Product operation
Short	Open	Forced thermo off operation
Open	Open	Normal operation
Open	Short	Heating / DHW setting temperature 1step-up operation
Short	Short	Heating / DHW setting temperature 2step-up operation

CAUTION • These parts are optional and not included with the product.
• Turn off the ELCB first before connecting the SG Ready.

2023. 12
Ver.12

Samsung Electronics Co., LTD.

Head Office (Suwon Korea) 129, Samsung-Ro, Yeongtong-Gu, Suwon City, Gyeonggi-Do, Korea 16677
Website : www.samsung.com, <https://partnerhub.samsung.com> Email : airconditioner@samsung.com
Images and data in this book may subject to change without prior notice.